

DIMENSIONS

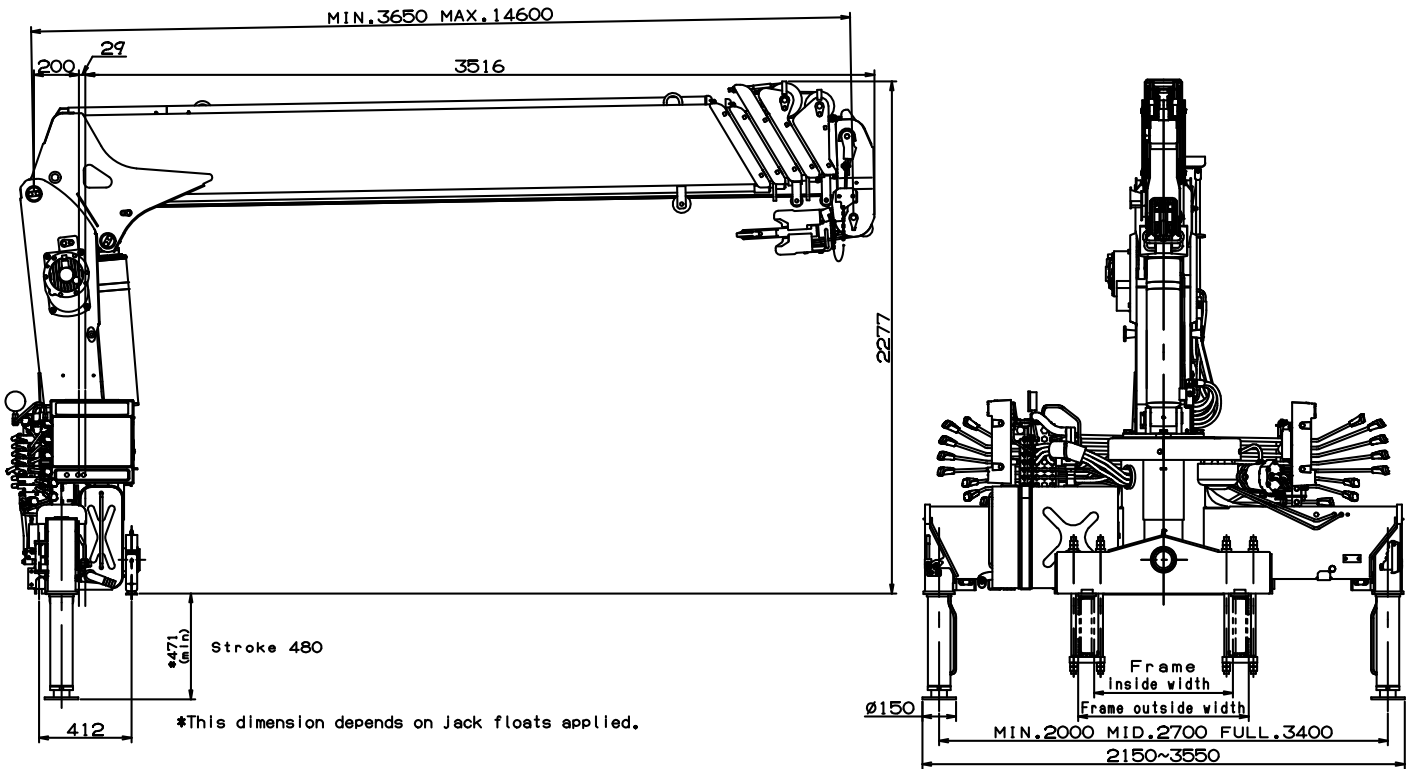

GENERAL DATA FOR SUITABLE TRUCKS

Gross vehicle weight	8,000 to 14,500 kg
P.T.O. torque	190 N·m {19.4 kgf·m} min.
P.T.O. revolution range of use (min. to max.)	Approx. 350 to 1,300 min ⁻¹ {rpm}
Width for crane mounting	Approx. 640 mm min.
Frame	Weight distribution and frame strength should be calculated for each truck
Frame width range (inside to outside)	Approx. 610 to 860 mm
Frame height (ground to chassis frame top) (*1)	Approx. 560 to 1,060 mm
Chassis frame section modulus (*2)	238 cm ³ min.

*1 Height of crane mounting surface is changed by crane bases.

*2 The chassis frame material must meet the following conditions at the crane mounting location.

— Yield point : 392 N/mm²

— Tensile strength : 540 N/mm²