

Table D

LOAD RADIUS	3.65 m / 5.87 m BOOM			LOAD RADIUS	8.07 m BOOM	
	CRANE STRENGTH	EMPTY CHASSIS			CRANE STRENGTH	EMPTY CHASSIS
		extension width of outriggers				
		MAX.	MIN.			
2.4 m and below	3,030	3,030	1,580	2.7 m and below	2,330	2,330
2.5 m	2,830	2,830	1,480	3.0 m	2,200	2,200
3.0 m	2,380	2,380	1,050	3.5 m	1,930	1,930
3.5 m	1,980	1,980	780	4.0 m	1,700	1,700
4.0 m	1,700	1,700	600	4.5 m	1,480	1,480
4.5 m	1,480	1,480	480	5.0 m	1,300	1,300
5.0 m	1,300	1,300	380	5.5 m	1,150	1,150
5.67 m	1,100	1,100	280	6.0 m	1,030	1,030
				6.5 m	930	930
				7.0 m	830	830
				7.87 m	700	700

LOAD RADIUS	10.25 m BOOM		LOAD RADIUS	12.4 m BOOM		LOAD RADIUS	14.6 m BOOM										
	CRANE STRENGTH	EMPTY CHASSIS extension width of outriggers MAX.		CRANE STRENGTH	EMPTY CHASSIS extension width of outriggers MAX.		CRANE STRENGTH	EMPTY CHASSIS extension width of outriggers MAX.									
									4.0 m and below	1,130	1,130	5.0 m and below	880	880	4.9 m and below	430	430
									5.0 m	1,050	1,050	6.0 m	730	730	6.0 m	380	380
6.0 m	880	880	7.0 m	630	630	7.0 m	330	330									
7.0 m	750	750	8.0 m	530	530	8.0 m	300	300									
8.0 m	650	650	9.0 m	480	480	9.0 m	280	280									
9.0 m	600	600	10.0 m	400	400	10.0 m	260	260									
10.05 m	500	500	11.0 m	380	380	11.0 m	240	240									
			12.2 m	330	330	12.0 m	220	220									
						13.0 m	200	200									
						14.4 m	180	180									

- NOTE :
1. Empty Chassis Rated Capacities in these tables depend on condition that crane is set level on firm level ground.
 2. This value includes the mass of lifting devices such as hook block (30kg).
 3. When the front outriggers are extended to the middle width, read the capacities rated for the minimum extension width.
 4. Fully extend the front outriggers when working with a boom length exceeding 5.87m.
 5. This load radius shows actual load radius which includes boom deflection.
 6. If the boom length exceeds the table value even a little, the performance is limited to the performance of the next boom length.
 7. When the boom length is 10.25 m, a half of the first \sphericalangle mark on lateral face of the 4th boom section is exposed out of 3rd boom section.
 8. When the boom length is 12.4 m, a half of the second \sphericalangle mark on lateral face of the 4th boom section is exposed out of 3rd boom section.
 9. Empty chassis rated lifting capacity varies according to the working area.
 - Front mounting <over-side, over-rear area> : 100%
 - <over-front area> : 25%
 10. Empty Chassis Rated Capacities table A, C and D depend on the types of chassis. (The following table shows guidelines for bodywork vehicles that can achieve the rated lifting capacity table A and C for vehicles. The rated lifting capacity may not be applicable depending on vehicle specifications. Be sure to carry out a stability inspection to determine which rated lifting capacity tables to apply.)

A	8.0 t ≤ GVW < 14.5 t (Must be set up the rear outrigger.)
C	11.0 t ≤ GVW < 14.5 t, 4200 mm ≤ WB (*1) (Must be set up the rear outrigger.)

*1 : From the front axle to the farthest rear axle.

Extension mark

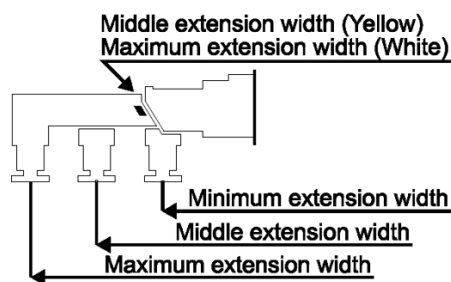

Front mounting

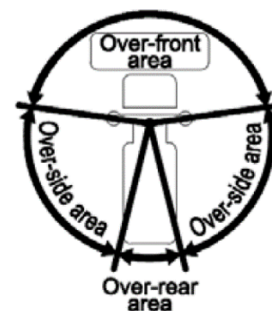

WORKING RANGE

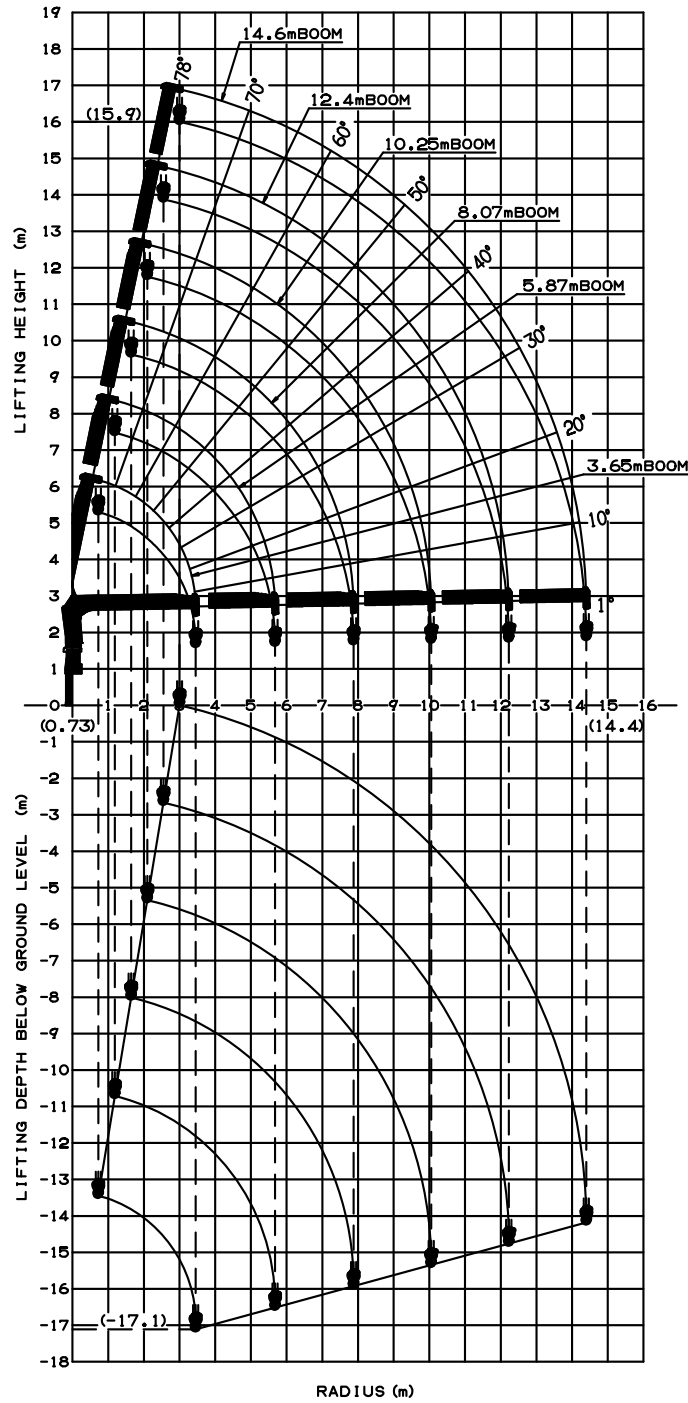

NOTE : The above lifting heights and boom angles are based on a straight (unladen) boom, and allowance should be made for boom deflection obtained under laden conditions.

DIMENSIONS

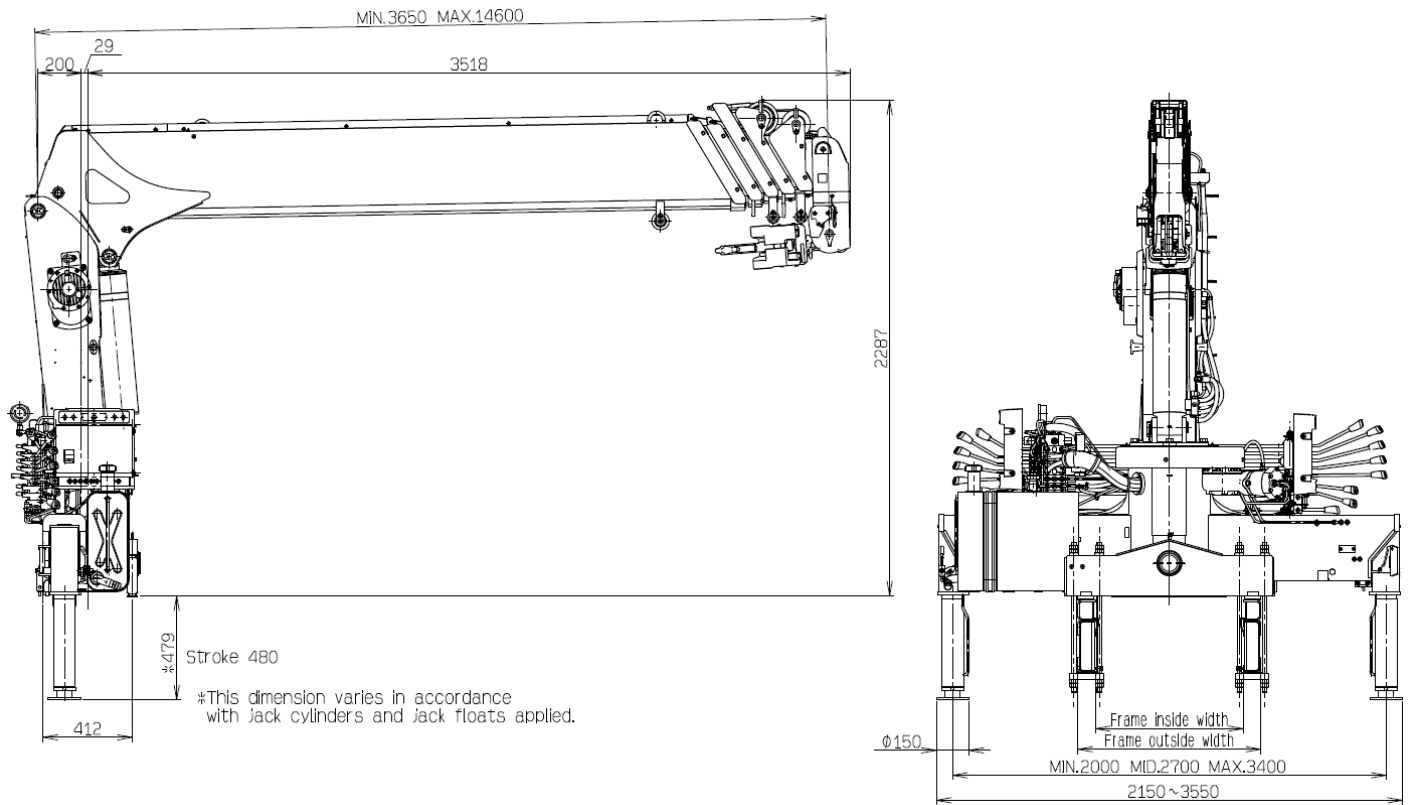

GENERAL DATA FOR SUITABLE TRUCKS

Even within range of this data, bodywork may not be possible depending on the specifications of the truck.

Gross vehicle weight	8,000 to 14,500 kg
P.T.O. torque	190 N·m {19.4 kgf·m} min.
P.T.O. revolution range of use (min. to max.)	Approx. 350 to 1,300 min ⁻¹ {rpm}
Width for crane mounting	Approx. 640 mm min.
Frame	Weight distribution and frame strength should be calculated for each truck
Frame width range (inside to outside)	Approx. 610 to 860 mm
Frame height (ground to chassis frame top) (*1)	Approx. 655 to 785 mm
Chassis frame section modulus (*2)	238 cm ³ min.

*1 Height of crane mounting surface is changed by crane bases.

*2 The chassis frame material must meet the following conditions at the crane mounting location.

- Yield point : 392 N/mm²
- Tensile strength : 540 N/mm²