

TADANO CARGO CRANE

MODEL : **TM-ZE363HRS**

CRANE SPECIFICATIONS

<u>CRANE CAPACITY</u>	3,030 kg at 2.6 m (4-part lines)
<u>BOOM</u>	Three-sectioned, fully hydraulic telescoping boom of pentagonal box construction Retracted length ----- 3.28 m Extended length ----- 7.71 m Extending speed ----- 4.43 m / 12 s Elevation ----- Elevated by a double-acting hydraulic cylinder Elevating speed ----- 1° to 78° / 7.5 s Boom point ----- 2 sheaves
<u>WINCH</u>	Hydraulic motor driven Spur gear speed reduction, provided with mechanical brake Single line pull ----- 7.45 kN {760 kgf} Single line speed ----- 76 m/min (at 4th layer) Wire rope Diameter x length --- 8 mm x 51 m Breaking strength --- 43.1 kN {4.39 tf} Construction ----- 7 x 7 + 6 x WS(26) Hook block ----- 2 sheaves
<u>HOOK STOWING DEVICE</u>	Mechanically stowed beneath boom top portion

<u>SWING</u>	<p>Hydraulic motor driven Worm gear speed reduction Continuous 360° full circle swing on ball bearing slew ring Automatic swing lock Swing speed ----- 2.5 min⁻¹{rpm}</p>
<u>OUTRIGGERS</u>	<p>Manually extended sliders and hydraulically extended jacks Integral with crane frame Power up and down Extension width ---- Min. 2,000 mm Mid. 2,700 mm, 3,400 mm Full 4,200 mm</p>
<u>HYDRAULICS</u>	<p>Hydraulic pump ----- Single gear pump Hydraulic motors ----- Axial piston type for winch Axial piston type for swing Control valves ----- Multiple control valves with integral safety valve Oil tank capacity ----- approx. 31 L</p>
<u>RADIO CONTROLLER</u>	<p>Model : RCS-F (Approved by NCC LP0002) Control functions of boom telescoping, hoisting up and down, boom elevating, swing, acceleration, speed mode selection, Hook-in, Hook-out, horn and emergency stop Frequency ----- 5 frequencies in 433 MHz band Operating power supply Transmitter ----- 6V DC, Dry battery R6P(SUM-3) x 4 Control unit ----- 24V DC, Vehicle battery Transmitter mass ---- Approx. 569 g (includes batteries)</p>
<u>SAFETY DEVICES</u>	<p>AML(Automatic Moment Limiter) Load indication Load moment ratio to rated load indication Warning alarm Over load limiter WHL(Working Height Limiter) Load meter Load indicator Emergency stop switch on radio controller Terminal for emergency stop switch Over-winding alarm Hoisting limiter P.T.O indicator lamp Hook safety latch Hydraulic safety valves, check valves and holding valves Level gauge</p>
<u>CRANE MASS</u>	Approx. 1,265 kg (includes standardized mounting parts)

NOTE : Operating speeds of the crane are guaranteed under the condition that the pump delivery is 60 L/min.

RATED LIFTING CAPACITIES IN KILOGRAMS

Crane Strength Rated Capacities

Load Radius	3.28 m / 5.51 m Boom		Load Radius	7.71 m Boom
	Extension width of outriggers			Extension width of outriggers
	Full	Minimum		Full
2.3 m and below	3,030	1,430	2.7 m and below	2,330
2.6 m	3,030	1,150	3.2 m	2,030
3.0 m	2,580	930	3.5 m	1,830
3.5 m	2,180	730	4.0 m	1,630
4.0 m	1,880	580	4.5 m	1,480
4.5 m	1,680	480	5.0 m	1,330
5.0 m	1,480	430	5.5 m	1,230
5.3 m	1,380	380	6.0 m	1,130
			6.5 m	1,050
			7.0 m	980
			7.5 m	930

- NOTES : 1. The mass of hook block (30kg), slings and all similarly used load handling devices must be added to the mass of the load.
2. The above numerical values of total rated loads are based on crane strength only. The total rated loads based on stability may lower than those in the above table depending on the loading conditions and the types of the chassis.

Empty Chassis Rated Capacities

Table A

Load Radius	3.28 m / 5.51 m Boom		Load Radius	7.71 m Boom
	Extension width of outriggers			Extension width of outriggers
	Full	Minimum		Full
2.3 m and below	3,030	1,330	2.7 m and below	2,330
2.6 m	3,030	1,100	3.2 m	2,030
3.0 m	2,480	880	3.5 m	1,780
3.5 m	1,930	680	4.0 m	1,430
4.0 m	1,480	530	4.5 m	1,180
4.5 m	1,230	430	5.0 m	980
5.0 m	1,030	380	5.5 m	830
5.3 m	980	330	6.0 m	730
			6.5 m	650
			7.0 m	580
			7.5 m	530

Table C

Load Radius	3.28 m / 5.51 m Boom		Load Radius	7.71 m Boom
	Extension width of outriggers			Extension width of outriggers
	Full	Minimum		Full
2.3 m and below	3,030	1,430	2.7 m and below	2,330
2.6 m	3,030	1,150	3.2 m	2,030
3.0 m	2,480	930	3.5 m	1,780
3.5 m	2,030	730	4.0 m	1,480
4.0 m	1,730	580	4.5 m	1,280
4.5 m	1,430	480	5.0 m	1,130
5.0 m	1,180	430	5.5 m	1,030
5.3 m	1,080	380	6.0 m	880
			6.5 m	780
			7.0 m	700
			7.5 m	650

Table D

Load Radius	3.28 m / 5.51 m Boom		Load Radius	7.71 m Boom
	Extension width of outriggers			Extension width of outriggers
	Full	Minimum		Full
2.3 m and below	3,030	1,430	2.7 m and below	2,330
2.6 m	3,030	1,150	3.2 m	2,030
3.0 m	2,580	930	3.5 m	1,830
3.5 m	2,180	730	4.0 m	1,630
4.0 m	1,880	580	4.5 m	1,480
4.5 m	1,680	480	5.0 m	1,330
5.0 m	1,480	430	5.5 m	1,230
5.3 m	1,380	380	6.0 m	1,130
			6.5 m	1,050
			7.0 m	980
			7.5 m	930

- NOTES :
1. Empty Chassis Rated Capacities in these tables depend on condition that crane is set level on firm level ground.
 2. The mass of hook block (30 kg), slings and all similarly used load handling devices must be added to the mass of load.
 3. For boom lengths not shown, use the rated lifting capacity of next longer boom.
 4. When outriggers are extended to middle extension width, use the rated lifting capacities for outriggers are extended to minimum extension width.
 5. For boom lengths longer than 5.51m, extend outriggers to full extension width.
 6. Empty Chassis Rated Capacities table A , C and D depend on the types of chassis.
 7. Empty Chassis Rated Capacities are shown for over-side areas and over-rear area. These capacities for over-front area may lowered depending on the types of chassis.

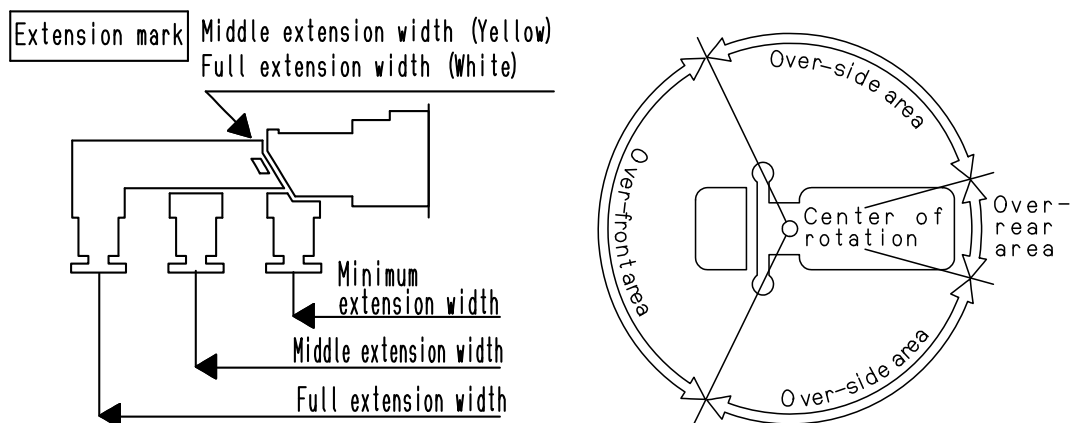

WORKING RANGE

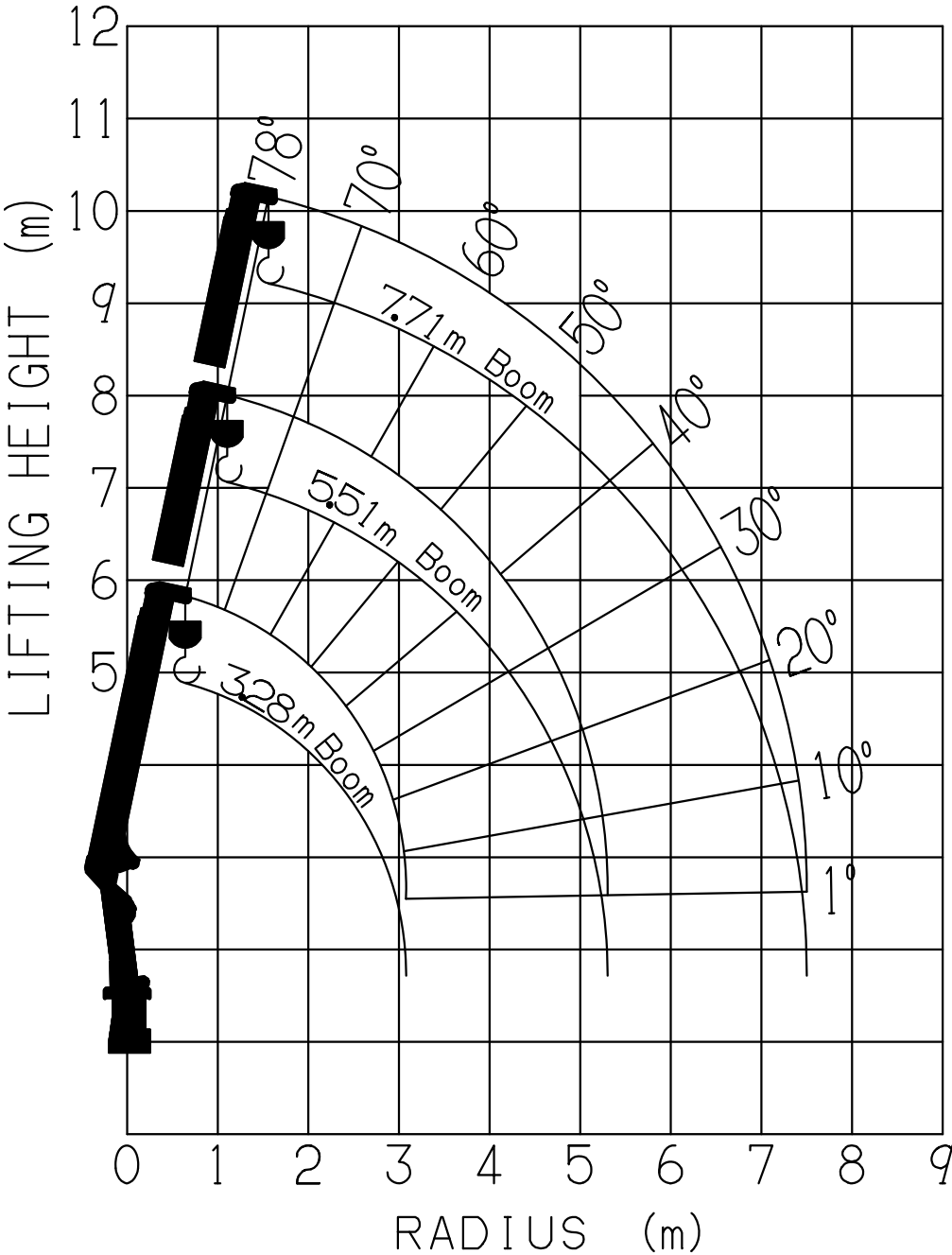

NOTE : The above lifting heights and boom angles are based on a straight (unladen) boom, and allowance should be made for boom deflection obtained under laden conditions.

DIMENSIONS

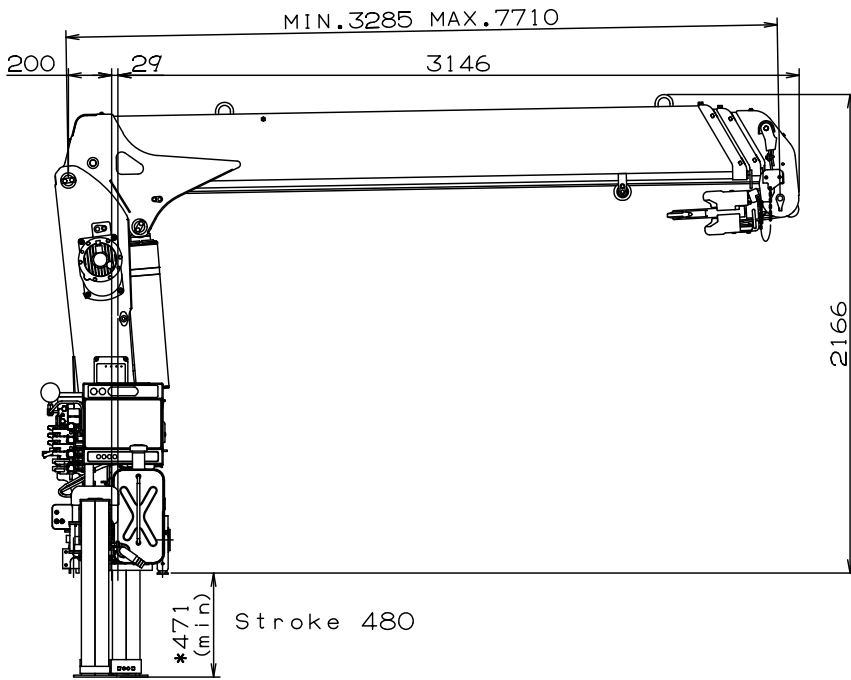

* This dimension varies in accordance with Jack floats applied.

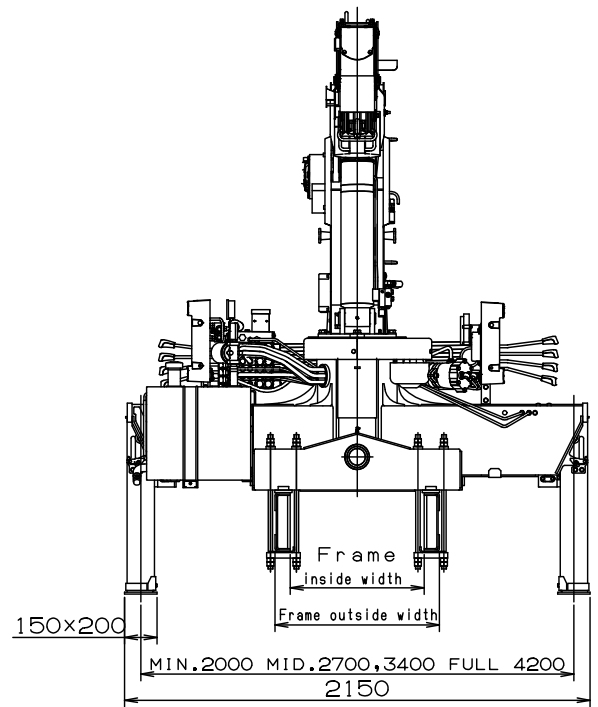

GENERAL DATA FOR SUITABLE TRUCKS

- Gross vehicle mass (including crane mass) ----- 8,000 to 15,000 kg
 - P.T.O. torque ----- 190 N-m{19.4 kgf-m} min.
 - P.T.O. revolution ----- Approx. 300 to 1,900 min⁻¹{rpm}
 - Width for crane mounting ----- Approx. 640 mm min.
 - Frame ----- Weight distribution and frame strength should be calculated for each truck
 - Frame width range (inside to outside) ----- Approx. 610 to 860 mm
 - Frame height (ground to frame top) ----- Approx. 1,070 mm max.
- (Height of crane mounting base can be changed by combination of jack floats and crane bases)