

## TADANO CARGO CRANE

MODEL : **TM-ZE365HS**

## CRANE SPECIFICATIONS

CRANE CAPACITY

3,000 kg at 2.4 m (4-part lines)

BOOM

Five-sectioned, fully powered partly synchronized telescoping boom of heptagonal box construction

Retracted length ----- 3.52 m

Extended length ----- 12.3 m

Extending speed ----- 8.78 m / 18 s

Elevation ----- Elevated by a double-acting hydraulic cylinder

Elevating speed ----- 1° to 78° / 7.5 s

Boom point ----- 2 sheaves

WINCH

Hydraulic motor driven Spur gear speed reduction, provided with mechanical brake and cable follower

Single line pull ----- 7.35 kN{750 kgf}

Single line speed ----- 76 m/min (at 4th layer)

Wire rope

Diameter x length --- 8 mm x 74 m

Breaking strength ---43.1 kN{4.39 tf}

Construction ----- 7 x 7 + 6 x WS(26)

Hook block ----- 2 sheaves

HOOK STOWING DEVICE

Mechanically stowed beneath boom top portion

Specifications are subject to change without notice.

SLEWING

Hydraulic motor driven Worm gear speed reduction Continuous  
 360° full circle slewing on ball bearing slew ring  
 Automatic slewing lock  
 Slewing speed ----- 2.5 min<sup>-1</sup>{rpm}

OUTRIGGERS

Manually extended sliders and hydraulically extended jacks  
 Integral with crane frame Power up and down  
 Extension width ----- Min. 2,000 mm  
 Mid. 2,900 mm, 3,600mm  
 Max. 4,200 mm

HYDRAULICS

Hydraulic pump ----- Single gear pump  
 Hydraulic motors ----- Axial piston type for winch  
 Axial piston type for slewing  
 Control valves ----- Multiple control valves with integral  
 safety valve  
 Oil tank capacity ----- approx. 31 L

SAFETY DEVICES

AML(Automatic Moment Limiter)  
 Load indication  
 Load moment ratio to rated load indication  
 Warning alarm  
 Over load limiter (stop)  
 WHL(Working Height Limiter)  
 Load meter  
 Load indicator  
 Over-unwinding prevention  
 Terminal for emergency stop switch  
 Over-winding alarm  
 Anti-two-block device  
 Hook safety latch  
 Hydraulic safety valves, check valves and holding valves  
 Level gauge

CRANE MASS

Approx. 1,500 kg (includes standardized mounting parts)

NOTE : Operating speeds of the crane are guaranteed under the condition that the pump delivery is 60 L /min.

## RATED LIFTING CAPACITIES IN KILOGRAMS

### Crane Strength Rated Capacities

Load Radius	3.52 m / 5.75 m Boom	Load Radius	7.95 m Boom	Load Radius	10.12 m Boom	Load Radius	12.3 m Boom
2.4 m and below	3,000	2.7 m and below	2,300	4.0 m and below	1,200	4.5 m and below	900
2.5 m	2,800	3.0 m	2,100	5.0 m	950	5.0 m	800
3.0 m	2,400	3.5 m	1,800	6.0 m	800	6.0 m	670
3.5 m	2,000	4.0 m	1,600	7.0 m	700	7.0 m	570
4.0 m	1,700	4.5 m	1,450	8.0 m	620	8.0 m	470
4.5 m	1,450	5.0 m	1,300	9.0 m	550	9.0 m	420
5.0 m	1,300	5.5 m	1,120	9.92m	500	10.0m	370
5.55m	1,120	6.0 m	1,050			11.0m	320
		6.5 m	950			12.1m	300
		7.0 m	850				
		7.75m	720				

- NOTES :
1. Capacities in above tables include slings and similarly used load lifting devices, and they must be added to the mass of the load. They don't, however, include the mass of hook block (30kg)
  2. The above numerical values of total rated loads are based on crane strength only. The total rated loads based on stability may lower than those in the above table depending on the loading conditions, the types of the chassis and extension width of outriggers.

Table A Empty Chassis Rated Capacities

Load Radius	3.52 m / 5.75 m Boom		Load Radius	7.95 m Boom	Load Radius	10.12 m Boom	Load Radius	12.3 m Boom
	Extension width of outriggers			Extension width of outriggers		Extension width of outriggers		Extension width of outriggers
	Maximum	Minimum		Maximum		Maximum		Maximum
2.4 m and below	3,000	1,300	2.7 m and below	2,300	4.0 m and below	1,200	4.5 m and below	900
2.5 m	2,750	1,200	3.0 m	2,100	5.0 m	950	5.0 m	800
3.0 m	2,300	850	3.5 m	1,800	6.0 m	750	6.0 m	670
3.5 m	1,950	650	4.0 m	1,550	7.0 m	550	7.0 m	550
4.0 m	1,570	500	4.5 m	1,250	8.0 m	420	8.0 m	420
4.5 m	1,250	400	5.0 m	1,020	9.0 m	350	9.0 m	350
5.0 m	1,020	300	5.5 m	870	9.92m	300	10.0m	270
5.55m	820	250	6.0 m	750			11.0m	250
			6.5 m	620			12.1m	200
			7.0 m	550				
			7.75m	480				

Table C

Load Radius	3.52 m / 5.75 m Boom		Load Radius	7.95 m Boom	Load Radius	10.12 m Boom	Load Radius	12.3 m Boom
	Extension width of outriggers			Extension width of outriggers		Extension width of outriggers		Extension width of outriggers
	Maximum	Minimum		Maximum		Maximum		Maximum
2.4 m and below	3,000	1,550	2.7 m and below	2,300	4.0 m and below	1,200	4.5 m and below	900
2.5 m	2,800	1,450	3.0 m	2,100	5.0 m	950	5.0 m	800
3.0 m	2,400	1,050	3.5 m	1,800	6.0 m	800	6.0 m	670
3.5 m	2,000	800	4.0 m	1,600	7.0 m	700	7.0 m	570
4.0 m	1,700	620	4.5 m	1,400	8.0 m	620	8.0 m	470
4.5 m	1,450	500	5.0 m	1,250	9.0 m	500	9.0 m	420
5.0 m	1,300	400	5.5 m	1,100	9.92m	420	10.0m	370
5.55m	1,120	320	6.0 m	1,000			11.0m	320
			6.5 m	870			12.1m	300
			7.0 m	770				
			7.75m	620				

Table D

Load Radius	3.52 m / 5.75 m Boom		Load Radius	7.95 m Boom	Load Radius	10.12 m Boom	Load Radius	12.3 m Boom
	Extension width of outriggers			Extension width of outriggers		Extension width of outriggers		Extension width of outriggers
	Maximum	Minimum		Maximum		Maximum		Maximum
2.4 m and below	3,000	1,550	2.7 m and below	2,300	4.0 m and below	1,200	4.5 m and below	900
2.5 m	2,800	1,450	3.0 m	2,100	5.0 m	950	5.0 m	800
3.0 m	2,400	1,050	3.5 m	1,800	6.0 m	800	6.0 m	670
3.5 m	2,000	800	4.0 m	1,600	7.0 m	700	7.0 m	570
4.0 m	1,700	620	4.5 m	1,450	8.0 m	620	8.0 m	470
4.5 m	1,450	500	5.0 m	1,300	9.0 m	550	9.0 m	420
5.0 m	1,300	400	5.5 m	1,120	9.92m	500	10.0m	370
5.55m	1,120	320	6.0 m	1,050			11.0m	320
			6.5 m	950			12.1m	300
			7.0 m	850				
			7.75m	720				

- NOTES :
1. Empty Chassis Rated Capacities in these tables depend on condition that crane is set level on firm level ground.
  2. Capacities in these tables include slings and similarly used load handling devices, and they must be added to the mass of the load. They don't, however, include the mass of hook block (30kg).
  3. When the outriggers are extended to the middle extension width, read the capacities rated for the minimum extension width.
  4. This load radius shows actual load radius which includes boom deflection.
  5. If the boom length exceeds the table value even a little, the performance is limited to the performance of the next boom length.
  6. For boom lengths longer than 5.75m, extend outriggers to maximum extension width.
  7. When the boom length is 10.12 m, a half of the  $\square$  mark on lateral face of the 4th boom section is exposed out of the 3rd boom section.
  8. Empty Chassis Rated Capacities table A ,C and D depend on the types of chassis.
  9. Empty Chassis Rated Capacities are shown for over-side areas and over-rear area. These capacities for over-front area may lowered depending on the types of chassis.

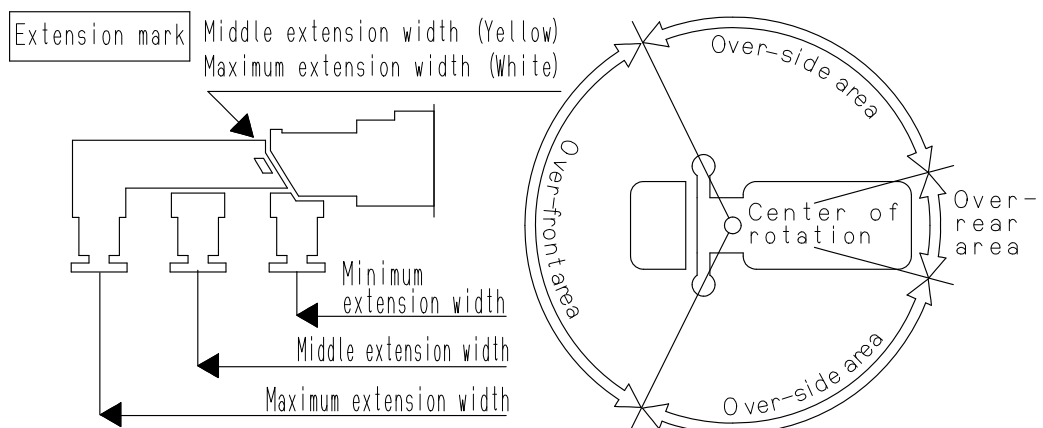

### WORKING RANGE

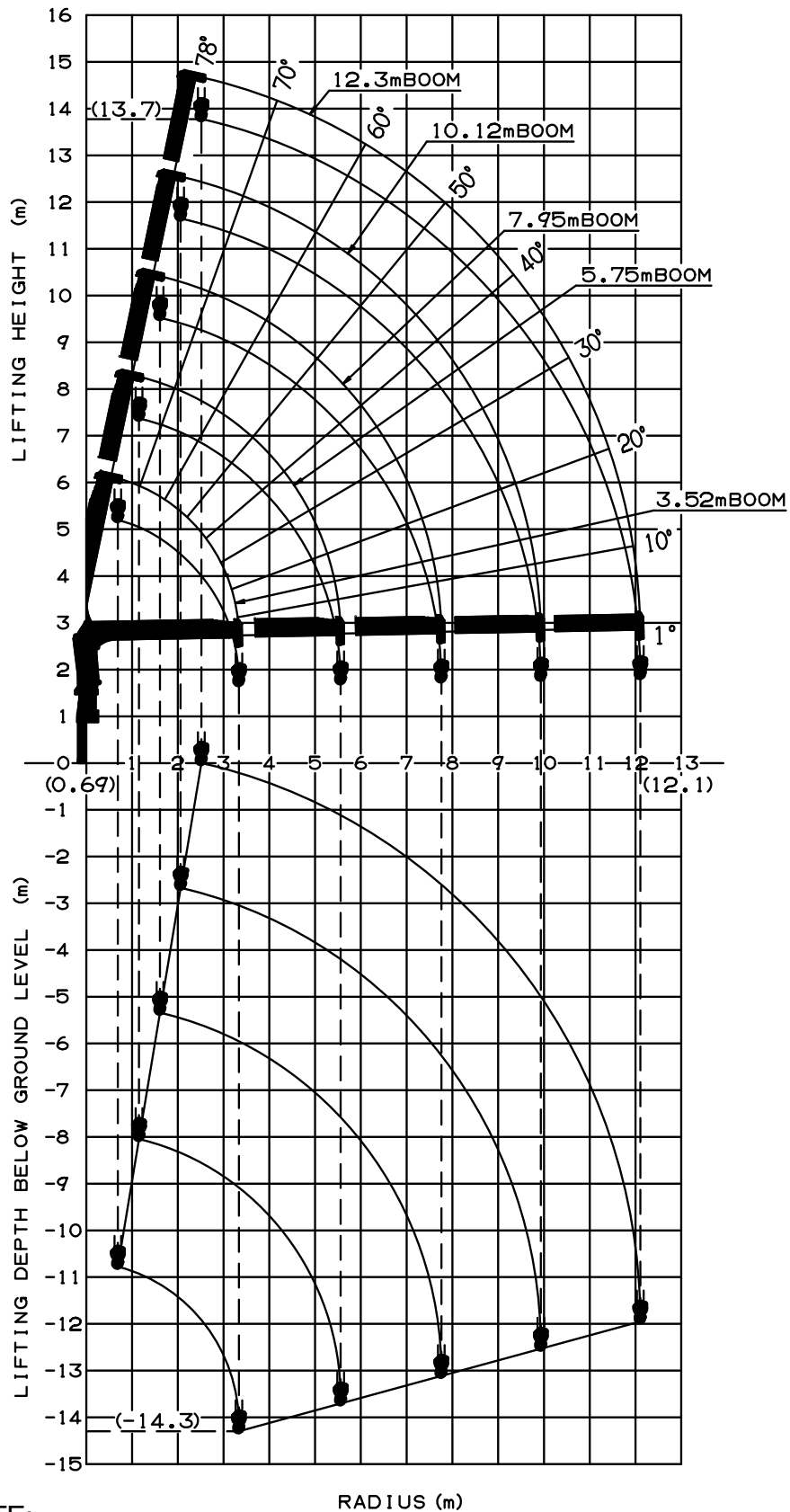

**NOTE:**

The above lifting heights and boom angles are based on a straight (unladen) boom, and allowance should be made for boom deflection obtained under laden conditions.

## DIMENSIONS

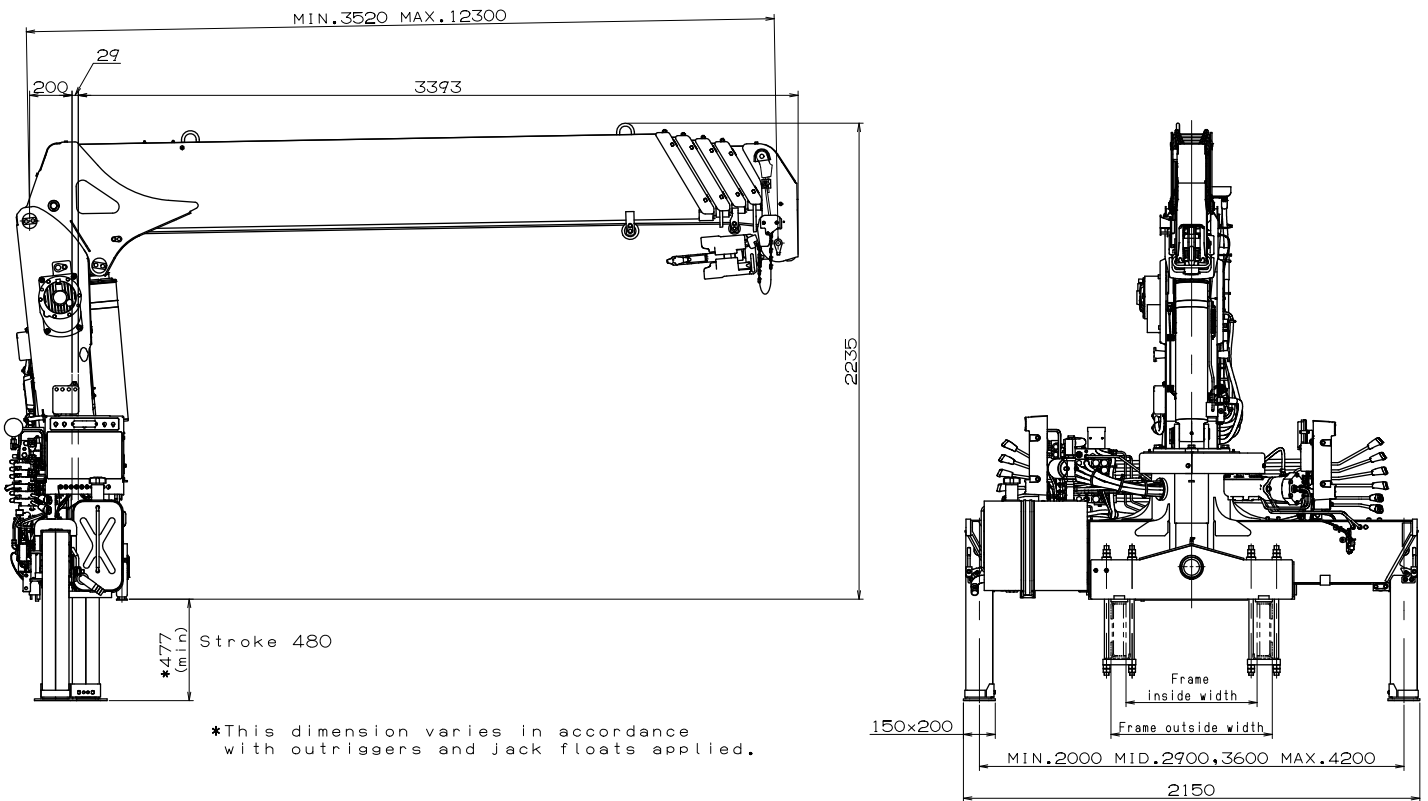

## GENERAL DATA FOR SUITABLE TRUCKS

- Gross vehicle mass (including crane mass) ----- 8,000 to 17,000 kg
  - P.T.O. torque ----- 190 N-m{19.4 kgf-m} min.
  - P.T.O. revolution ----- Approx. 300 to 1,900 min<sup>-1</sup>{rpm}
  - Width for crane mounting ----- Approx. 640 mm min.
  - Frame ----- Weight distribution and frame strength should be calculated for each truck
  - Frame width range (inside to outside) ----- Approx. 610 to 860 mm
  - Frame height (ground to frame top) ----- Approx. 1,055 mm max.
- (Height of crane mounting base can be changed by combination of jack floats and crane bases)