

TADANO CARGO CRANE

MODEL : **TM-ZE366HS**

CRANE SPECIFICATIONS

CRANE CAPACITY

3,000 kg at 2.3 m (4-part lines)

BOOM

Six-sectioned, fully powered partly synchronized telescoping boom of pentagonal box construction

Retracted length ----- 3.65 m

Extended length ----- 14.6 m

Extending speed ----- 10.95 m / 19 s

Elevation ----- Elevated by a double-acting hydraulic cylinder

Elevating speed ----- 1° to 78° / 7.5 s

Boom point ----- 2 sheaves

WINCH

Hydraulic motor driven Spur gear speed reduction, provided with mechanical brake and cable follower

Single line pull ----- 7.35 kN{750 kgf}

Single line speed ----- 76 m/min (at 4th layer)

Wire rope

Diameter x length ----- 8 mm x 85 m

Breaking strength ----- 43.1 kN{4.39 tf}

Construction ----- 7 x 7 + 6 x WS(26)

Hook block ----- 2 sheaves

HOOK STOWING DEVICE

Mechanically stowed beneath boom top portion

SWING Hydraulic motor driven Worm gear speed reduction
 Continuous 360° full circle swing on ball bearing slew ring
 Automatic swing lock
 Swing speed ----- 2.5 min⁻¹{rpm}

OUTRIGGERS Manually extended sliders and hydraulically extended jacks
 Integral with crane frame Power up and down
 Extension width ----- Min. 2,000 mm
 Mid. 2,700 mm, 3,400mm
 Full 4,200 mm

REAR OUTRIGGERS (Locally provided)
 Full extension width ---- Not less than 2,800 mm

HYDRAULICS Hydraulic pump ----- Single gear pump
 Hydraulic motors ----- Axial piston type for winch
 Axial piston type for swing
 Control valves ----- Multiple control valves with integral
 safety valve
 Oil tank capacity ----- approx. 31 L

SAFETY DEVICES AML(Automatic Moment Limiter)
 Load indication
 Load moment ratio to rated load indication
 Warning alarm
 Over load limiter
 WHL(Working Height Limiter)
 Load meter
 Load indicator
 Over-unwinding prevention
 Terminal for emergency stop switch
 Over-winding alarm
 Hoisting limiter
 P.T.O indicator lamp
 Hook safety latch
 Hydraulic safety valves, check valves and holding valves
 Level gauge

CRANE MASS Approx. 1,535 kg (with standardized mounting parts included)

NOTE : Operating speeds of the crane are guaranteed under the condition that the pump delivery is 60 L/min.

RATED LIFTING CAPACITIES IN KILOGRAMS

Crane Strength Rated Capacities

Load Radius	3.65 m / 5.87 m Boom		Load Radius	8.07 m Boom Extension width of outriggers Full	Load Radius	10.2 m Boom Extension width of outriggers Full	Load Radius	12.4 m Boom Extension width of outriggers Full	Load Radius	14.6 m Boom Extension width of outriggers Full
	Extension width of outriggers									
	Full	Minimum								
2.3 m and below	3,000	1,350	2.7 m and below	2,300	4.0 m and below	1,000	5.0 m and below	670	4.9 m and below	370
2.5 m	2,800	1,200	3.0 m	2,100	5.0 m	850	6.0 m	550	6.0 m	330
3.0 m	2,350	850	3.5 m	1,850	6.0 m	700	7.0 m	470	7.0 m	300
3.5 m	1,950	650	4.0 m	1,600	7.0 m	600	8.0 m	400	8.0 m	270
4.0 m	1,650	500	4.5 m	1,420	8.0 m	550	9.0 m	350	9.0 m	250
4.5 m	1,420	400	5.0 m	1,250	9.0 m	480	10.0 m	300	10.0m	230
5.0 m	1,250	300	5.5 m	1,100	10.05m	450	11.0 m	270	11.0m	210
5.67m	1,050	250	6.0 m	970			12.22m	250	12.0m	190
			6.5 m	850					13.0m	170
			7.0 m	770					14.4m	150
			7.87m	650						

- NOTES : 1. Capacities in above tables include slings and similarly used load handling devices, and they must be added to the mass of the load. They don't, however, include the mass of hook block (30kg)
2. The above numerical values of total rated loads are based on crane strength only. The total rated loads based on stability may lower than those in the above table depending on the loading conditions and the types of the chassis.

Table A Empty Chassis Rated Capacities

Load Radius	3.65 m / 5.87 m Boom		Load Radius	8.07 m Boom Extension width of outriggers Full	Load Radius	10.2 m Boom Extension width of outriggers Full	Load Radius	12.4 m Boom Extension width of outriggers Full	Load Radius	14.6 m Boom Extension width of outriggers Full
	Extension width of outriggers									
	Full	Minimum								
2.3 m and below	3,000	1,250	2.7 m and below	2,200	4.0 m and below	1,000	5.0 m and below	600	4.9 m and below	300
2.5 m	2,750	1,100	3.0 m	2,000	5.0 m	800	6.0 m	450	6.0 m	250
3.0 m	2,250	750	3.5 m	1,650	6.0 m	670	7.0 m	370	7.0 m	220
3.5 m	1,850	550	4.0 m	1,350	7.0 m	500	8.0 m	320	8.0 m	200
4.0 m	1,400	450	4.5 m	1,150	8.0 m	400	9.0 m	280	9.0 m	180
4.5 m	1,150	350	5.0 m	950	9.0 m	320	10.0 m	250	10.0m	160
5.0 m	950	250	5.5 m	800	10.05m	270	11.0 m	220	11.0m	140
5.67m	790	200	6.0 m	670			12.22m	180	12.0m	130
			6.5 m	570					13.0m	110
			7.0 m	500					14.4m	100
			7.87m	420						

Table C

Load Radius	3.65 m / 5.87 m Boom		Load Radius	8.07 m Boom Extension width of outriggers Full	Load Radius	10.2 m Boom Extension width of outriggers Full	Load Radius	12.4 m Boom Extension width of outriggers Full	Load Radius	14.6 m Boom Extension width of outriggers Full
	Extension width of outriggers									
	Full	Minimum								
2.3 m and below	3,000	1,350	2.7 m and below	2,200	4.0 m and below	1,000	5.0 m and below	600	4.9 m and below	300
2.5 m	2,750	1,200	3.0 m	2,000	5.0 m	800	6.0 m	450	6.0 m	250
3.0 m	2,250	850	3.5 m	1,650	6.0 m	700	7.0 m	370	7.0 m	220
3.5 m	1,900	650	4.0 m	1,350	7.0 m	570	8.0 m	320	8.0 m	200
4.0 m	1,600	500	4.5 m	1,150	8.0 m	450	9.0 m	280	9.0 m	180
4.5 m	1,300	400	5.0 m	1,020	9.0 m	370	10.0 m	250	10.0m	160
5.0 m	1,050	300	5.5 m	850	10.05m	300	11.0 m	220	11.0m	140
5.67m	850	250	6.0 m	750			12.22m	200	12.0m	130
			6.5 m	650					13.0m	110
			7.0 m	570					14.4m	100
			7.87m	470						

Table D

Load Radius	3.65 m / 5.87 m Boom		Load Radius	8.07 m Boom	Load Radius	10.2 m Boom	Load Radius	12.4 m Boom	Load Radius	14.6 m Boom	
	Extension width of outriggers			Extension width of outriggers		Extension width of outriggers		Extension width of outriggers		Extension width of outriggers	Extension width of outriggers
	Full	Minimum		Full		Full		Full		Full	Full
2.3 m and below	3,000	1,350	2.7 m and below	2,300	4.0 m and below	1,000	5.0 m and below	670	4.9 m and below	370	
2.5 m	2,800	1,200	3.0 m	2,100	5.0 m	850	6.0 m	550	6.0 m	330	
3.0 m	2,350	850	3.5 m	1,850	6.0 m	700	7.0 m	470	7.0 m	300	
3.5 m	1,950	650	4.0 m	1,600	7.0 m	600	8.0 m	400	8.0 m	270	
4.0 m	1,650	500	4.5 m	1,420	8.0 m	550	9.0 m	350	9.0 m	250	
4.5 m	1,420	400	5.0 m	1,250	9.0 m	480	10.0 m	300	10.0m	230	
5.0 m	1,250	300	5.5 m	1,100	10.05m	450	11.0 m	270	11.0m	210	
5.67m	1,050	250	6.0 m	970			12.22m	250	12.0m	190	
			6.5 m	850					13.0m	170	
			7.0 m	770					14.4m	150	
			7.87m	650							

- NOTES :
1. Empty Chassis Rated Capacities in these tables depend on condition that crane is set level on firm level ground.
 2. Capacities in these tables include slings and similarly used load handling devices, and they must be added to the mass of the load. They don't, however, include the mass of hook block (30kg).
 3. For boom lengths not shown, use the rated lifting capacity of next longer boom.
 4. When outriggers are extended to middle extension width, use the rated lifting capacities for outriggers are extended to minimum extension width .
 5. For boom lengths longer than 5.87m, extend outriggers to full extension width.
 6. When the boom length is 10.2 m, a half of the first \square mark on lateral face of the 4th boom section is exposed out of the 3rd boom section.
 7. When the boom length is 12.4 m, a half of the second \square mark on lateral face of the 4th boom section is exposed out of the 3rd boom section.
 8. Empty Chassis Rated Capacities table A ,C and D depend on the types of chassis.
 9. Empty Chassis Rated Capacities are shown for over-side areas and over-rear area. These capacities for over-front area may lowered depending on the types of chassis.

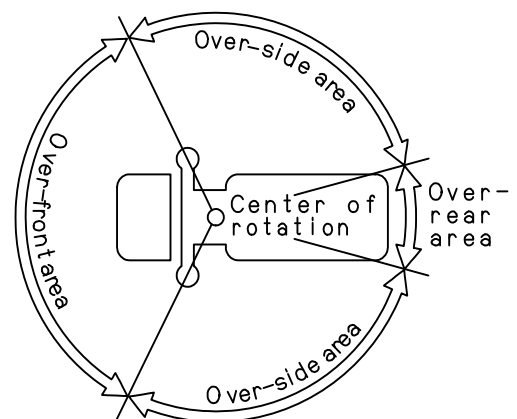
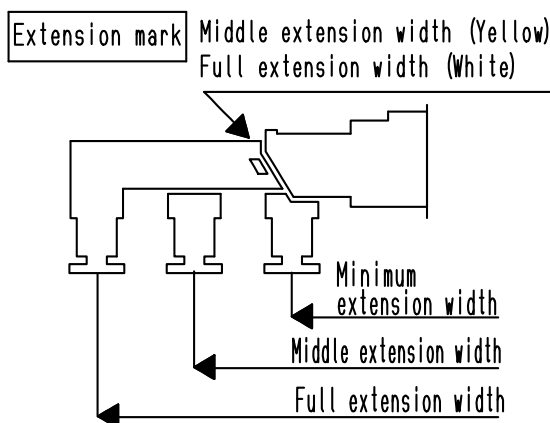

WORKING RANGE

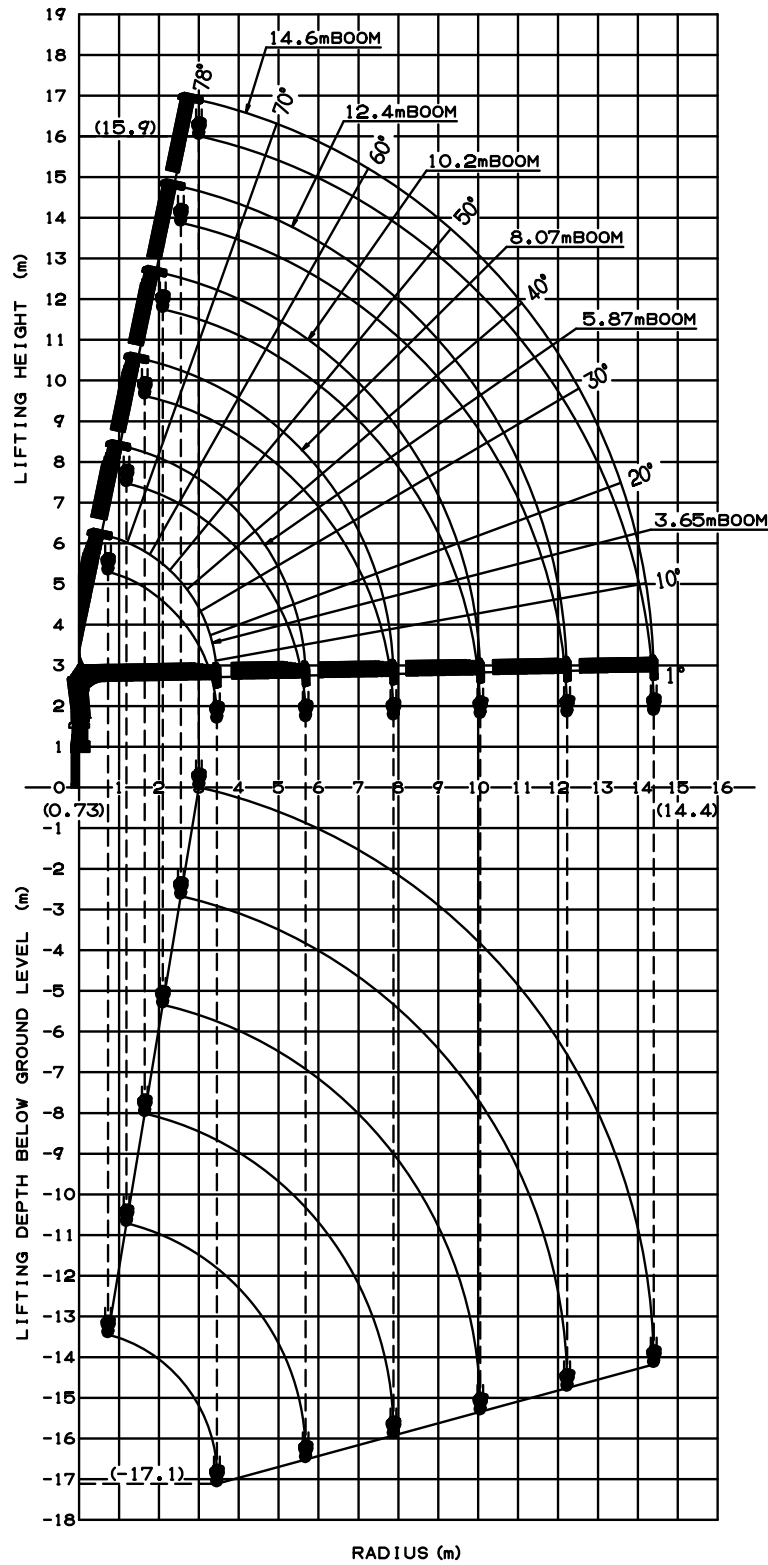

NOTE:

The above lifting heights and boom angles are based on a straight (unladen) boom, and allowance should be made for boom deflection obtained under laden conditions.

DIMENSIONS

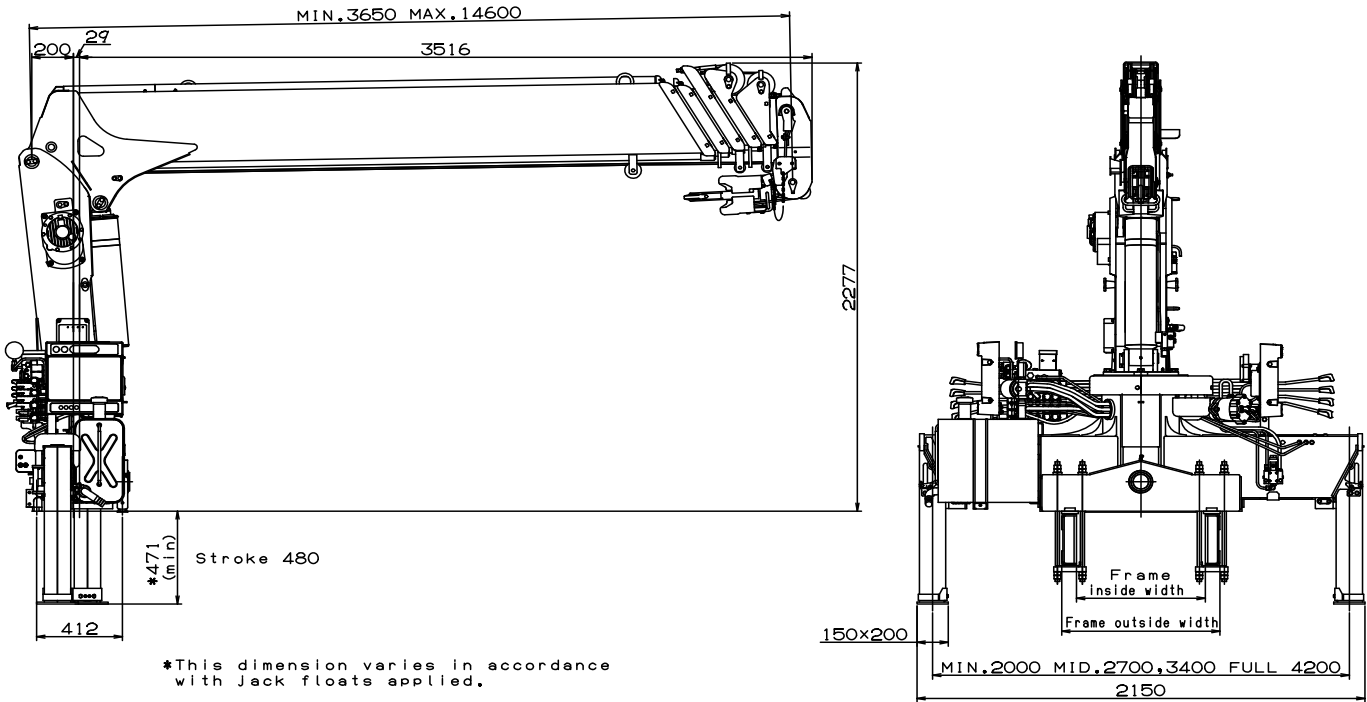

GENERAL DATA FOR SUITABLE TRUCKS

- Gross vehicle mass (including crane mass) ----- 8,000 to 15,000 kg
- P.T.O. torque -----190 N-m{19.4 kgf-m} min.
- P.T.O. revolution ----- Approx. 300 to 1,900 min⁻¹{rpm}
- Width for crane mounting ----- Approx. 640 mm min.
- Frame ----- Weight distribution and frame strength should be calculated for each truck
- Frame width range (inside to outside) ----- Approx. 610 to 860 mm
- Frame height (ground to frame top) ----- Approx. 1,070 mm max.
(Height of crane mounting base can be changed by combination of jack floats and crane bases)