























DIMENSIONS  
[TM-ZE555HRS]

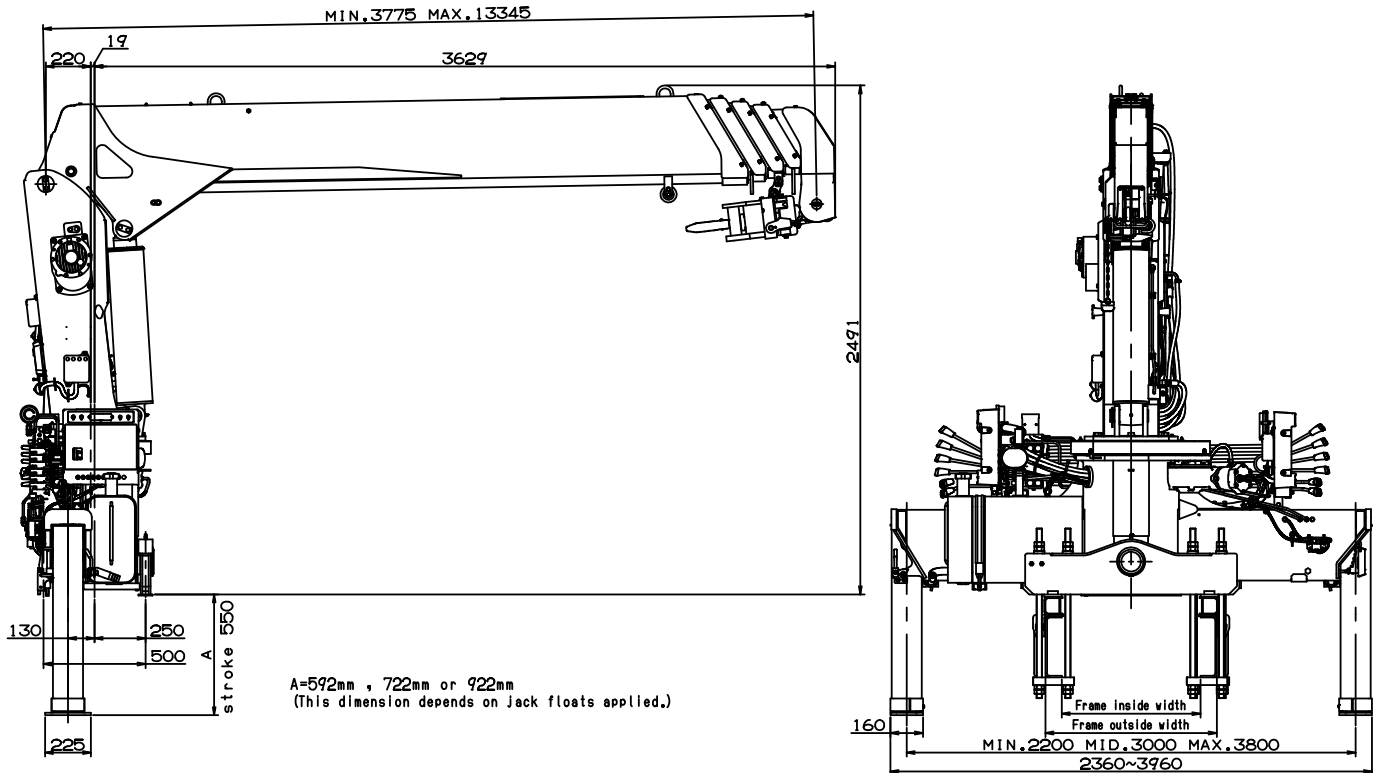

GENERAL DATA FOR SUITABLE TRUCKS

Gross vehicle weight	15,000 kg min.
Chassis front axle weight (excluding crane and mounting parts mass)	2,900 kg min.
P.T.O. torque	190 N·m {19.4 kgf·m} min.
P.T.O. revolution range of use (min. to max.)	Approx. 350 to 1,300 min <sup>-1</sup> {rpm}
Width for crane mounting	Approx. 750 mm min.
Frame	Weight distribution and frame strength should be calculated for each truck
Frame width range (inside to outside)	Approx. 610 to 960 mm
Frame height (ground to chassis frame top) (*1)	Approx. 880 to 1,145 mm
Chassis frame section modulus (*2)	485 cm <sup>3</sup> min.

\*1 Height of crane mounting surface is changed by crane bases.

\*2 The chassis frame material must meet the following conditions at the crane mounting location.

—Yield point : 392 N/mm<sup>2</sup>

—Tensile strength : 540 N/mm<sup>2</sup>