

TADANO CARGO CRANE

MODEL : **TM-ZR605G(HS)**

CRANE SPECIFICATIONS

MAXIMUM LIFTING CAPACITY 6,000 kg at 2.4 m (4-part lines)

CRANE CAPACITY 4,840 kg at 3.1 m (4-part lines)

BOOM Five-sectioned, fully powered partly synchronized telescoping boom

Retracted length ----- 4.40 m

Extended length -----15.92 m

Extending speed ----- 11.5 m / 30 s

Elevation ----- Elevated by a double-acting hydraulic cylinder

Elevating speed ----- 1° to 82° / 24 s

Boom point ----- 2 sheaves

WINCH Hydraulic motor driven Spur gear speed reduction, provided with mechanical brake and cable follower

Single line pull ----- 14.72 kN {1,500 kgf}

Single line speed ----- 64 m/min (at 4th layer)

Wire rope

Diameter x length --- 10 mm x 95 m

Breaking strength --- 73.5 kN {7.5 tf}

Construction ----- 7 x 7 + 6 x Fi(29)

Hook block ----- 2 sheaves

HOOK STOWING DEVICE Mechanically stowed beneath boom top portion

SWING Hydraulic motor driven Worm gear speed reduction Continuous
 360° full circle swing on ball bearing slew ring Automatic swing lock
 Swing speed ----- 2.5 min⁻¹ {rpm}

OUTRIGGERS Hydraulically extended sliders and hydraulically extended jacks
 Integral with crane frame Power up and down
 Extended width ----- Min. 2.25 m
 Mid. 3.10 m
 Max. 3.90 m

HYDRAULICS Hydraulic pump ----- Tandem gear pump
 Hydraulic motors ----- Axial piston type for winch
 Axial piston type for swing
 Control valves ----- Multiple control valves with integral
 safety valve
 Oil tank capacity ----- approx. 90 L

SAFETY DEVICES AML(Automatic Moment Limiter)
 Load indication
 Load moment ratio to rated load indication
 Warning alarm
 Over load limiter
 WHL(Working Height Limiter)
 Load indicator
 Over-unwinding prevention
 Terminal for emergency stop switch
 Over-winding alarm
 Hoisting limiter
 P.T.O indicator lamp
 Hook safety latch
 Hydraulic safety valves, check valves and holding valves
 Level gauge

CRANE MASS Approx. 2,955 kg (crane bare)

NOTE : Operating speeds of the crane are guaranteed under the condition that the pump
 delivery is 85 L/min.

RATED LIFTING CAPACITIES IN KILOGRAMS

Empty Chassis Rated Capacities

Table A

Load Radius	4.4 m / 7.28 m Boom		Load Radius	10.16 m Boom		Load Radius	13.04m Boom	Load Radius	15.92m Boom
	Outriggers Extended			Outriggers Extended			Outriggers Extended		Outriggers Extended
	Full	Minimum		Full	Minimum		Full		Full
2.4 m and below	6,000	2,940	2.4 m and below	2,940	2,940	4.0 m and below	2,940	4.7 m and below	2,540
3.1 m	4,840	2,440	3.1 m	2,940	2,440	5.0 m	2,240	6.0 m	1,640
3.5 m	4,140	2,040	3.5 m	2,940	2,040	6.0 m	1,640	7.0 m	1,240
4.0 m	3,640	1,540	4.0 m	2,940	1,540	7.0 m	1,240	8.0 m	990
4.5 m	2,640	1,240	4.5 m	2,590	1,190	8.0 m	990	9.0 m	790
5.0 m	2,290	940	5.0 m	2,240	940	9.0 m	790	10.0 m	690
6.0 m	1,740	690	6.0 m	1,640	690	10.0 m	690	11.0 m	590
7.03 m	1,340	440	7.0 m	1,240	440	11.0 m	590	12.0 m	440
			8.0 m	990	340	12.0 m	440	13.0 m	340
			9.0 m	790	240	12.7 m	340	14.0 m	290
			9.91 m	690	140			15.67 m	190

Table D

Load Radius	4.4 m / 7.28 m Boom		Load Radius	10.16 m Boom		Load Radius	13.04m Boom	Load Radius	15.92m Boom
	Outriggers Extended			Outriggers Extended			Outriggers Extended		Outriggers Extended
	Full	Minimum		Full	Minimum		Full		Full
2.4 m and below	6,000	2,940	2.4 m and below	2,940	2,940	4.5 m and below	2,940	5.0 m and below	2,540
3.1 m	4,840	2,540	3.1 m	2,940	2,540	5.0 m	2,540	6.0 m	1,940
3.5 m	4,140	2,090	3.5 m	2,940	2,090	6.0 m	1,940	7.0 m	1,590
4.0 m	3,640	1,640	4.0 m	2,940	1,640	7.0 m	1,640	8.0 m	1,290
4.5 m	3,240	1,290	4.5 m	2,940	1,290	8.0 m	1,290	9.0 m	1,040
5.0 m	2,840	1,040	5.0 m	2,640	1,040	9.0 m	1,040	10.0 m	890
6.0 m	2,140	740	6.0 m	2,140	740	10.0 m	890	11.0 m	790
7.03 m	1,640	490	7.0 m	1,690	490	11.0 m	790	12.0 m	640
			8.0 m	1,290	390	12.0 m	640	13.0 m	540
			9.0 m	1,040	290	12.7 m	540	14.0 m	440
			9.91 m	890	190			15.67 m	340

- NOTES :
1. Empty Chassis Rated Capacities in these tables depend on condition that crane is set level on firm level ground.
 2. Capacities in these tables include slings and similarly used load handling devices, and they must be added to the mass of the load. They don't , however, include the mass of hook block (60kg).
 3. For boom lengths not shown, use the rated lifting capacity of next longer boom.
 4. When outriggers are extended to middle extension width, use the rated lifting capacities for outriggers are extended to minimum extension width.
 5. For boom lengths longer than 10.16m, extend outriggers to maximum.
 6. 13.04m boom means \sphericalangle mark on 4th boom section side plate is half seen.
 7. Empty Chassis Rated Capacities table A and D depend on the types of chassis.
 8. Empty Chassis Rated Capacities are shown for over - side areas and over - rear area.
These capacities for over - front area may lowered depending on the types of chassis.

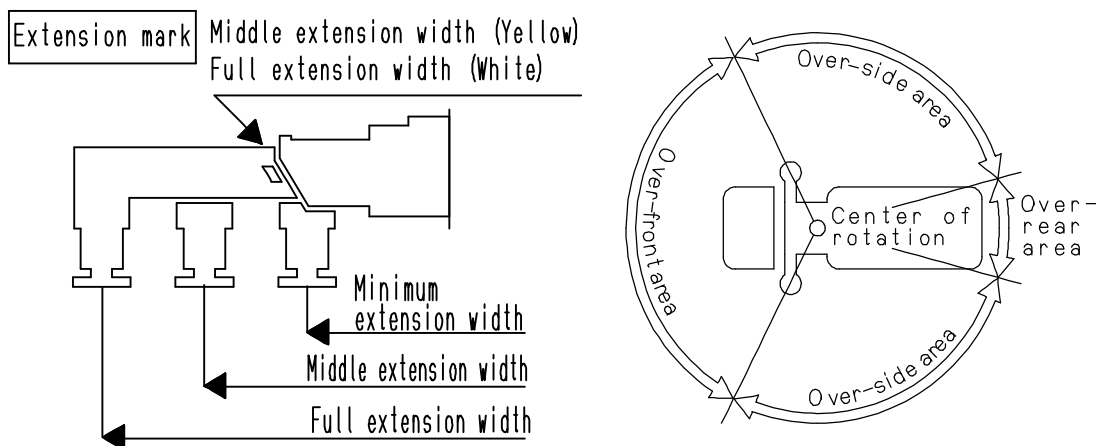

WORKING RANGE

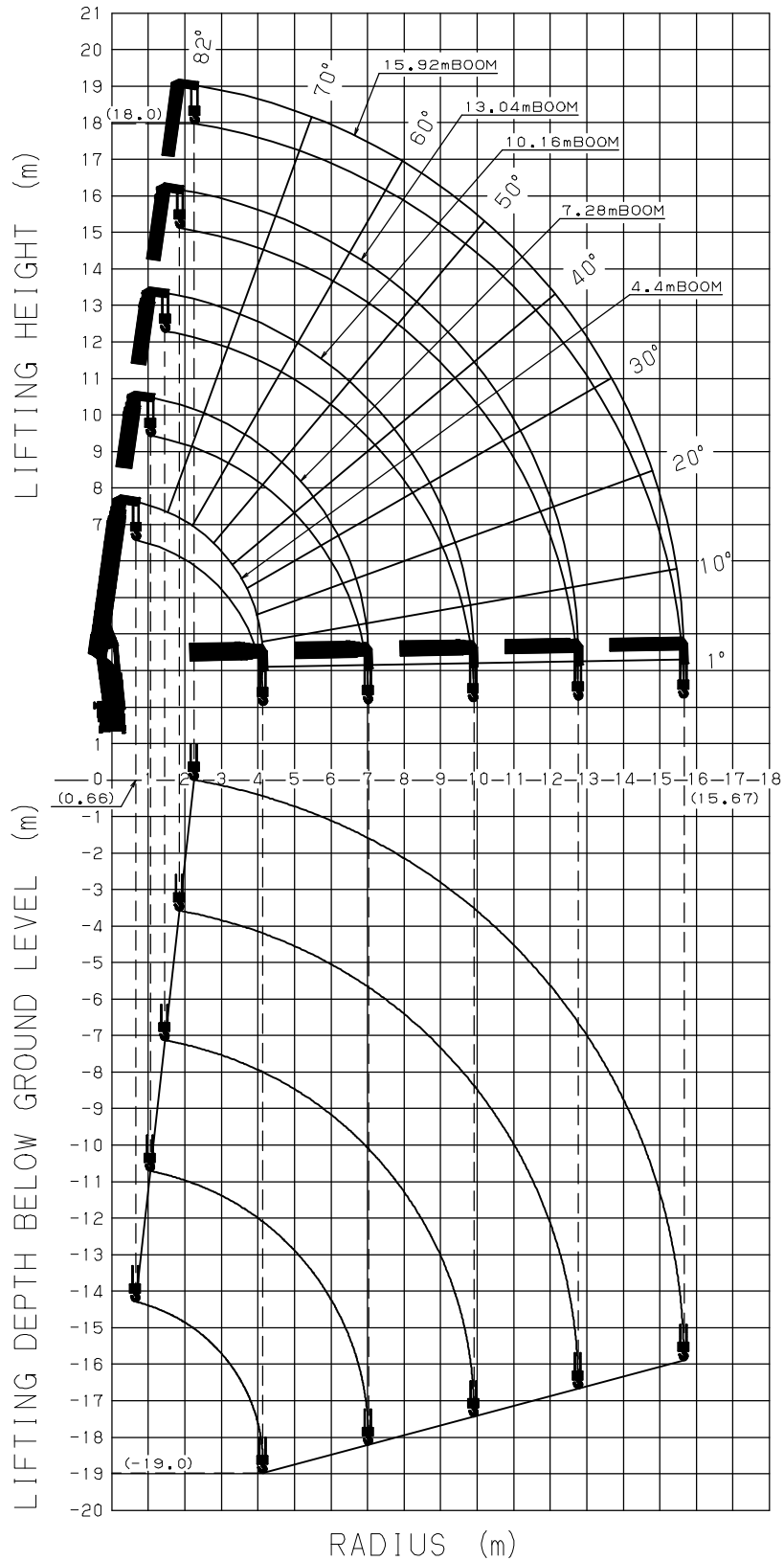

NOTE: The above lifting heights and boom angles are based on a straight (unladen) boom, and allowance should be made for boom deflection obtained under laden conditions.

DIMENSIONS

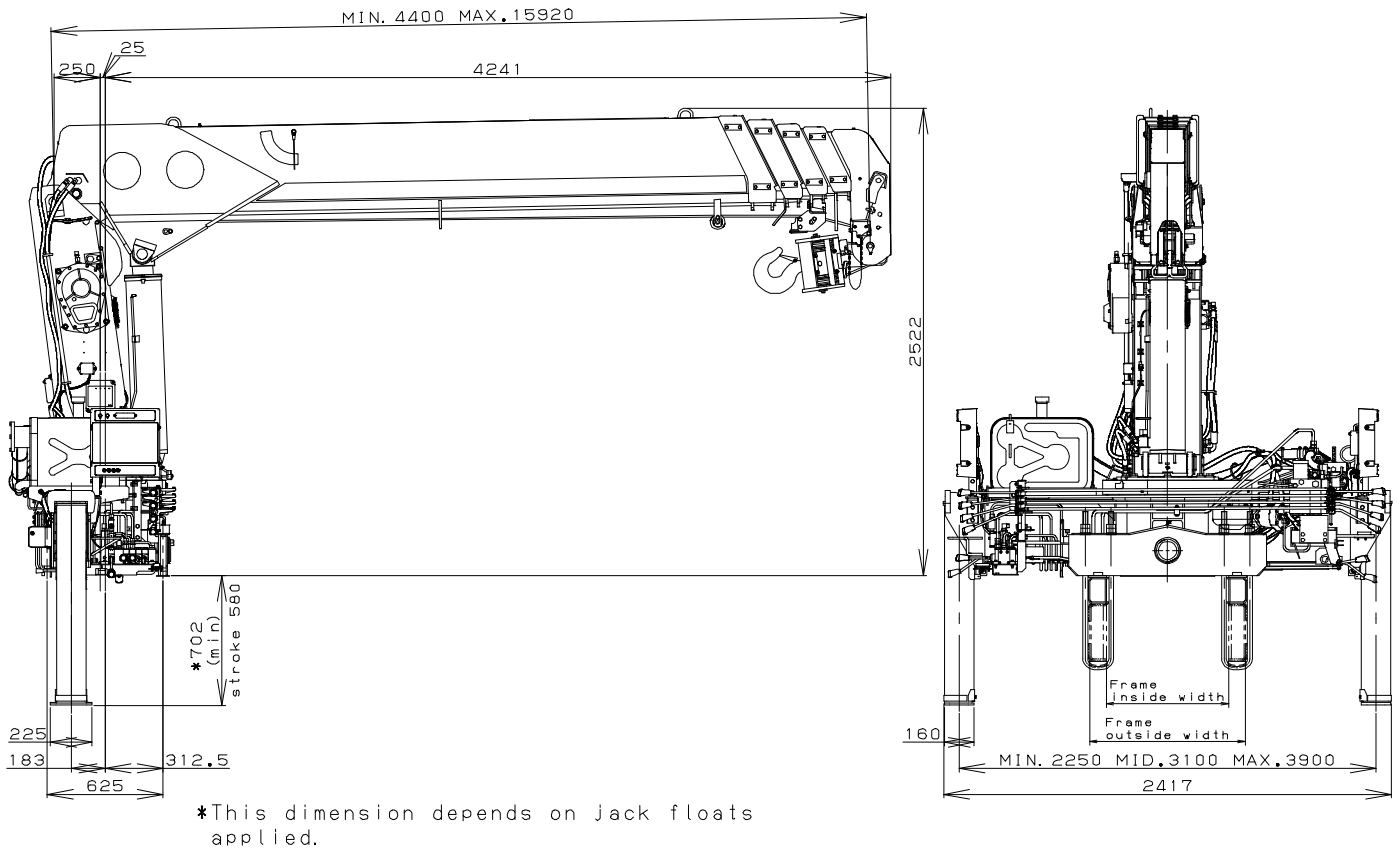

GENERAL DATA FOR SUITABLE TRUCKS

- Gross vehicle mass (including crane mass) ----- 20,000 to 25,000 kg
 - P.T.O. torque ----- 245 N-m{25 kgf-m} min.
 - P.T.O. revolution ----- Approx. 270 to 2,800 min⁻¹{rpm}
 - Width for crane mounting ----- Approx. 1,000 mm min.
 - Frame ----- Weight distribution and frame strength should be calculated for each truck
 - Frame width range (inside to outside) ----- Approx. 576 to 953 mm
 - Frame height (ground to frame top) ----- Approx. 1,055 mm max.
- (Height of crane mounting base can be changed by combination of jack floats and crane bases)