

TADANO CARGO CRANE

MODEL : **TM-ZT503**

CRANE SPECIFICATIONS

CRANE CAPACITY

5,050 kg at 2.5 m (5-part line)

BOOM

Three-sectioned, fully hydraulic telescoping boom of pentagonal box construction

Retracted length ----- 3.47 m

Extended length ----- 8.31 m

Extending speed ----- 4.84 m / 18 s

Elevation ----- Elevated by a double-acting hydraulic cylinder

Elevating speed ----- 1° to 78° / 12 s

Boom point ----- 3 sheaves

WINCH

Hydraulic motor driven Spur gear speed reduction, provided with mechanical brake

Single line pull ----- 9.90 kN{1,010 kgf}

Single line speed ----- 66 m/min.(at 4th layer)

Wire rope

Diameter x length ----- 8 mm x 67 m

Breaking strength ----- 50.1 kN{5,100 kgf}

Construction ----- 7 x 7 + 6 x WS(26)

Hook block ----- 2 sheaves

RATED LIFTING CAPACITIES IN KILOGRAMS

Crane Strength Rated Capacities

Load Radius	3.47 m Boom	Load Radius	5.91 m Boom	Load Radius	8.31 m Boom
2.5 m and below	5,050	2.95 m and below	4,050	3.8 m and below	3,130
2.95 m	4,050	3.8 m	3,130	4.1 m	2,930
3.25 m	3,700	4.1 m	2,930	4.5 m	2,580
		4.5 m	2,580	5.0 m	2,280
		5.0 m	2,280	5.5 m	2,030
		5.69 m	1,950	6.0 m	1,830
				6.5 m	1,680
				7.0 m	1,550
				7.5 m	1,430
				8.09m	1,280

- NOTES :
1. The above numerical values of total rated loads are based on crane strength only. The total rated loads based on stability may lower than those in the above table depending on the loading conditions and the types of the chassis.
 2. Rated Lifting Capacities in these tables depend on condition that crane is set level on firm level ground.
 3. The mass of hook block (50kg)、slings and all similarly used load lifting devices must be added to the mass of the load.
 4. For boom lengths not shown, use the rated lifting capacity of next longer boom.

WORKING RANGE

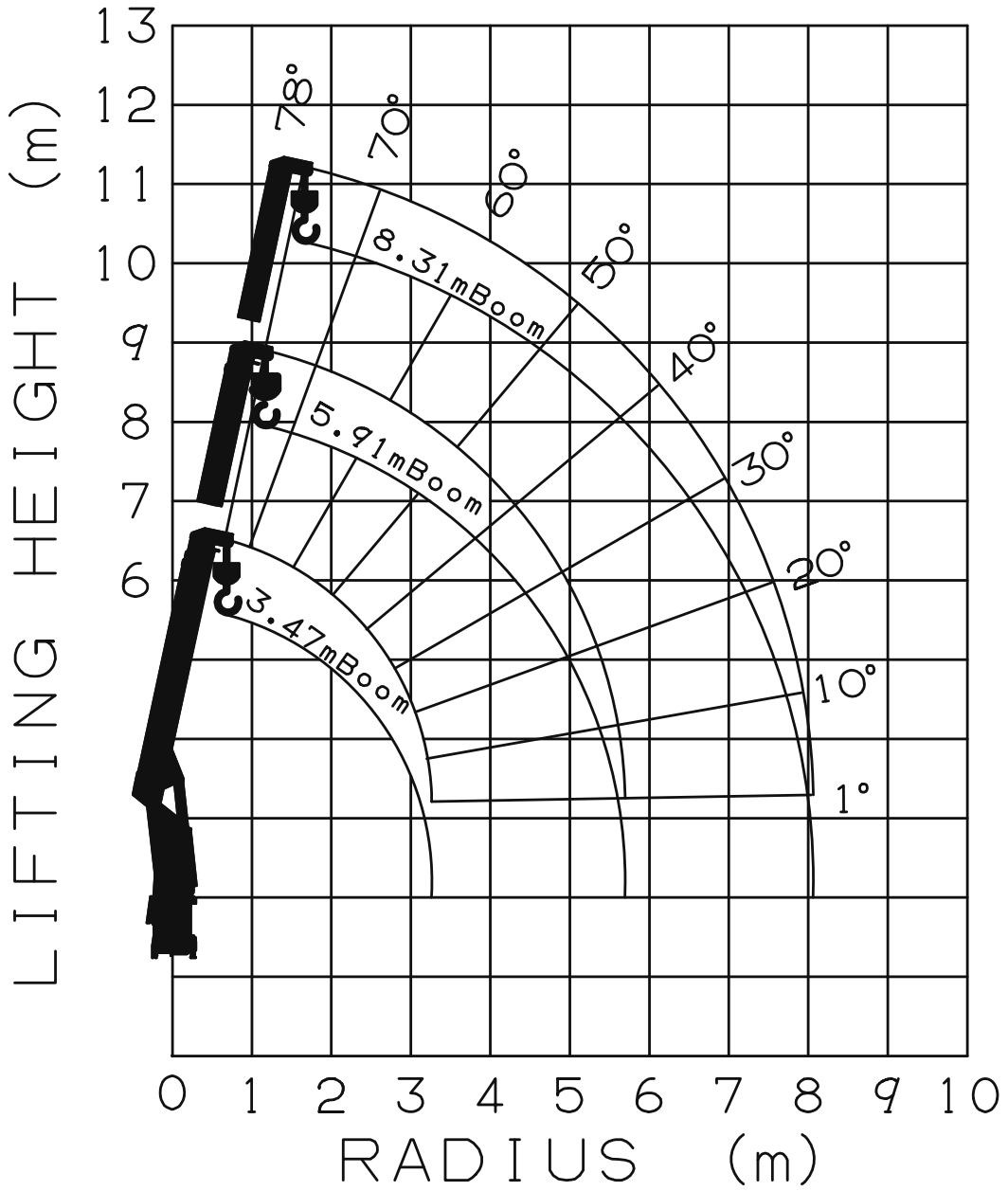

NOTE: The above lifting heights and boom angles are based on a straight (unladen) boom, and allowance should be made for boom deflection obtained under laden conditions.

DIMENSIONS

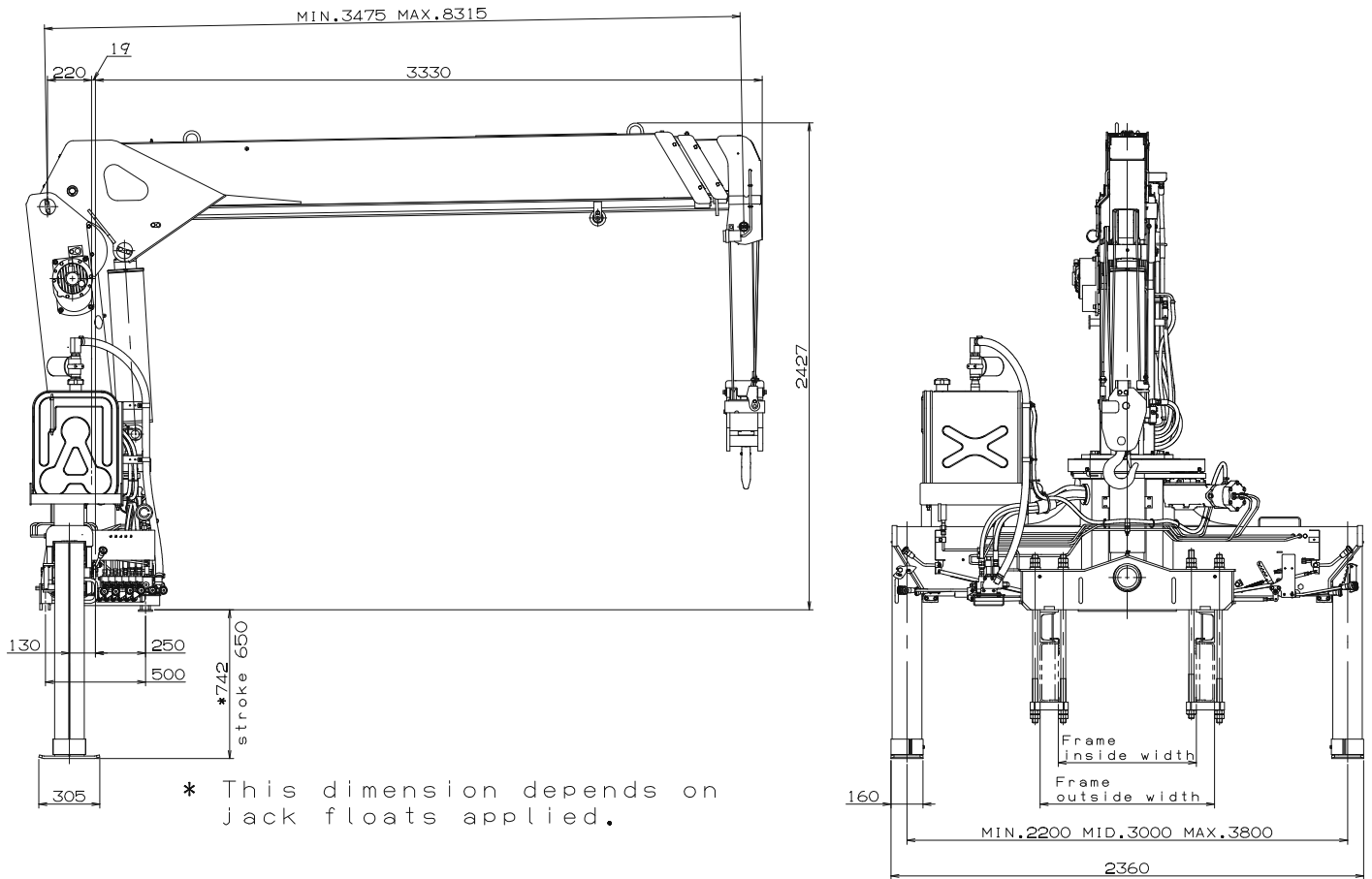

GENERAL DATA FOR SUITABLE TRUCKS

Gross vehicle mass (including crane mass) --- 15,000 kg or more

P.T.O. torque ----- 170 N·m{17.4 kgf·m} min.

P.T.O. revolution ----- Approx. 1,200 min⁻¹{rpm} max.

Width for crane mounting ----- Approx. 750 mm min.

Frame ----- Weight distribution and frame strength should be calculated for each truck

Frame width range (inside to outside) ----- Approx. 610 to 940 mm

Frame height (ground to frame top) ----- Approx. 1,290 mm max.

(Height of crane mounting base can be changed by combination of jack floats and crane bases)