

DIMENSIONS

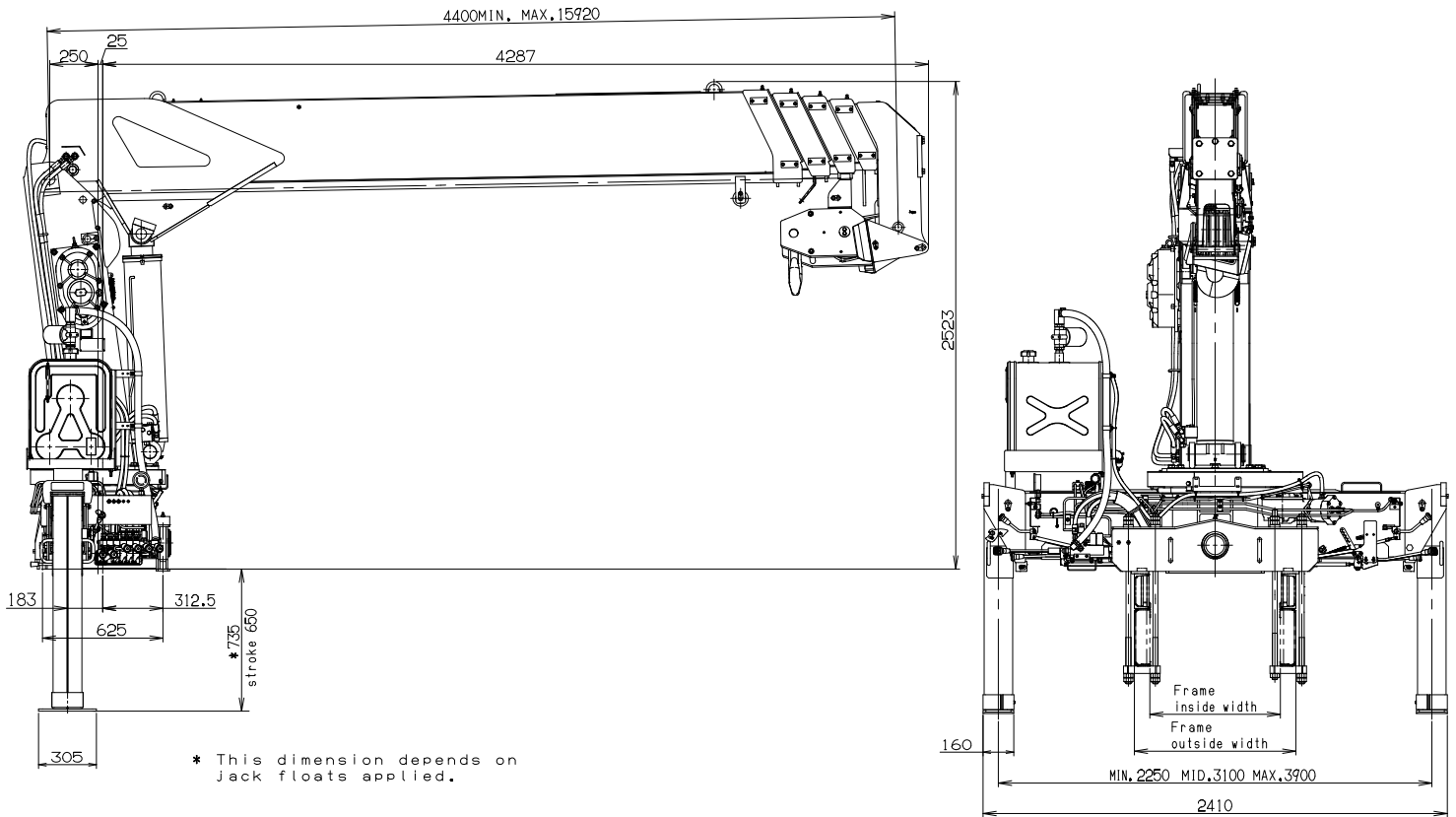

GENERAL DATA FOR SUITABLE TRUCKS

Gross vehicle mass (including crane mass)	25,000 kg or more
Chassis front axle weight (excluding crane mass)	3,000 kg min.
Wheel base (from the center of the front axle to the center of 2 rear axes.)	5,000 mm min.
P.T.O. torque	180 N·m{18.4 kgf·m} min.
P.T.O. revolution	Approx. 1,200 min ⁻¹ {rpm} max.
Width for crane mounting	Approx. 900 mm min.
Frame	Weight distribution and frame strength should be calculated for each truck
Frame width range (inside to outside)	Approx. 610 to 910 mm
Frame height (ground to frame top)	Approx. 1,280 mm max.(Height of crane mounting base can be changed by combination of jack floats and crane bases)