



TADANO ROUGH TERRAIN CRANE  
**MODEL : GR-800EX**

(Left-hand steering)

GENERAL DATA

<u>CRANE CAPACITY</u>		80,000 kg at 3.0 m
<u>BOOM</u>		5-section, 12.0 m — 47.0 m
<u>DIMENSION</u>		
Overall length	approx.	14,375 mm
Overall width	approx.	3,315 mm
Overall height	approx.	3,795 mm
<u>MASS</u>		
Gross vehicle mass	approx.	51,410 kg
-front axle	approx.	24,325 kg
-rear axle	approx.	27,085 kg
<u>PERFORMANCE</u>		
Max. traveling speed	computed	36 km/h
Gradeability (tan $\theta$ )	computed	94 % (at stall) *30 %

\* Machine should be operated within the limit of engine crankcase design (17° :MITSUBISHI 6M60-TL).

Specifications are subject to change without notice.

## CRANE SPECIFICATIONS

<u>MODEL</u>	GR-800EX
<u>CAPACITY</u>	80,000 kg at 3.0 m
<u>BOOM</u>	<p>Five section full power partially synchronized telescoping boom of round box construction with 6 sheaves at boom head. The synchronization system consists of 2 telescope cylinders, extension cables and retraction cables.</p> <p>Hydraulic cylinders fitted with holding valves.</p> <p style="padding-left: 40px;">Fully retracted length. . . . . 12.0 m</p> <p style="padding-left: 40px;">Fully extended length. . . . . 47.0 m</p> <p style="padding-left: 40px;">Extension speed. . . . . 35.0 m in 160 s</p>
<u>JIB</u>	<p>Two staged swingaround boom extension. Triple offset (3.5°/25°/45°) type. Stores alongside base boom section.</p> <p>Assistant cylinders for mounting and stowing.</p> <p>Single sheave at jib head.</p> <p style="padding-left: 40px;">Length. . . . . 10.1 m and 17.7 m</p>
<u>SINGLE TOP (AUXILIARY BOOM SHEAVE)</u>	<p>Single sheave.</p> <p>Mounted to main boom head for single line work.</p>
<u>ELEVATION</u>	<p>By a double-acting hydraulic cylinder, fitted with holding valve.</p> <p>Automatic speed reduction and soft stop function.</p> <p style="padding-left: 40px;">Boom angle . . . . . -1.5° to 80.5°</p> <p style="padding-left: 40px;">Boom raising speed . . . . . 20° to 60° in 46 s</p>
<u>HOIST - Main winch</u>	<p>Variable speed type with grooved drum driven by hydraulic axial piston motor through winch speed reducer. Power load lowering and hoisting. Equipped with automatic brake (Neutral brake) and counterbalance valve. Controlled independently of auxiliary winch.</p> <p style="padding-left: 40px;">Single line pull. . . . . 64.7 kN {6,600 kgf}</p> <p style="padding-left: 40px;">Single line speed(High). . . . . 149 m/min (at the 4th layer)</p> <p style="padding-left: 40px;">Single line speed(Low) . . . . . 107 m/min (at the 4th layer)</p> <p style="padding-left: 40px;">Wire rope. . . . . No-spin type</p> <p style="padding-left: 80px;">Diameter x length. . . . . 19 mm x 253 m</p>
<u>HOOK BLOCK(Optional) - 80 t capacity</u>	7 sheaves, swivel type hook with safety latch.
<u>HOOK BLOCK(Optional) - 60 t capacity</u>	6 sheaves, swivel type hook with safety latch.

- HOOK BLOCK(Optional) - 5 sheaves, swivel type hook with safety latch.  
50 t capacity
  
- HOOK BLOCK(Optional) - 3 sheaves, swivel type hook with safety latch.  
35 t capacity
  
- HOIST - Variable speed type with grooved drum driven by hydraulic axial piston  
Auxiliary winch motor through winch speed reducer. Power load lowering and hoisting.  
 Equipped with automatic brake (Neutral brake) and counterbalance  
 valve. Controlled independently of main winch.  
 Single line pull. . . . . 64.7 kN {6,600 kgf}  
 Single line speed(High). . . . . 149 m/min (at the 4th layer)  
 Single line speed(Low) . . . . . 107 m/min (at the 4th layer)  
 Wire rope. . . . . No-spin type  
 Diameter x length. . . . . 19 mm x 139 m
  
- HOOK BLOCK - Swivel hook with safety latch for single line use.  
6.6 t capacity
  
- SLEWING Hydraulic axial piston motor driven through planetary speed reducer.  
 Continuous 360° full circle slew on ball bearing slew ring.  
 Equipped with manually locked/released slewing brake.  
 Slewing speed. . . . . 1.5 min<sup>-1</sup> {rpm}
  
- HYDRAULIC SYSTEM Pumps. . . . . 2 variable piston pumps for telescoping, elevating  
 and winches.  
 Tandem gear pump for steering, slewing and  
 optional equipment.  
 Control valves. . . . Multiple valves actuated by pilot pressure with  
 integral pressure relief valves.  
 Circuit. . . . . Equipped with air cooled type oil cooler.  
 Oil pressure appears on AML display for main  
 circuit.  
 Hydraulic oil tank capacity. . .  
 approx. 840 liters  
 Filters. . . . . Return line filter
  
- CRANE CONTROL By 4 control levers for swing, boom hoist, main winch, boom telescoping  
 or auxiliary winch with 2 control pedals for boom hoist and boom  
 telescoping based on ISO standard layout. Control lever stands can  
 change neutral positions and tilt for easy access to cab.

CAB

Both crane and drive operations can be performed from one cab mounted on rotating superstructure. One sided one-man type, steel construction with sliding door access and tinted safety glass windows opening at side. Door window is powered control. Operator's 3 way adjustable seat with headrest and armrest. Hot water cab heater and air conditioning.

TADANO Automatic  
Moment Limiter  
(Model: AML-C)

Main unit in crane cab gives audible and visual warning of approach to overload. Automatically cuts out crane motions before overload. With working range (load radius and / or boom angle and/or tip height and / or slewing range) limit function.

Automatic Speed Reduction and Slow Stop function on boom elevation and slewing.

Following functions are displayed.

- Moment load as percentage
- Number of parts of line of rope
- Boom angle
- Boom length
- Load radius
- Outriggers position
- On-tire indicator
- Actual hook load
- Permissible load
- Boom position indicator
- Potential hook height
- Slewing angle
- Main hydraulic oil pressure
- Jib length and jib offset angle (only when jib operation)

OUTRIGGERS

Hydraulically operated H-type outriggers. Each outrigger controlled simultaneously or independently from the cab.

Equipped with sight level gauge. Floats mounted integrally with the jacks retract to within vehicle width.

All cylinders fitted with pilot check valves.

Crane operation with different extended length of each outrigger.

Equipped with extension width detector for each outrigger.

- Extended width
  - Fully. . . . . 7,300 mm
  - Middle. . . . . 6,700 mm
  - Middle. . . . . 5,500 mm
  - Minimum. . . . . 2,700 mm
- Float size (Diameter). . . . . 600 mm

COUNTERWEIGHT

Integral with swing frame (containing weight with auxiliary winch and wire rope)

- Mass. . . . . 9,980 kg

---

NOTE : Each crane motion speed is based on unladen conditions.

## CARRIER SPECIFICATIONS

<u>TYPE</u>	Rear engine, left hand steering, driving axle 2-way selected type (by manual switch). 4 x 2 front drive 4 x 4 front and rear drive
<u>FRAME</u>	High-tensile steel, all welded mono-box construction.
<u>ENGINE</u>	Model. . . . MITSUBISHI 6M60-TLC1B GB20891-2007 Type. . . . 4 cycle, turbo charged and after cooled, 6 cylinder in line, direct injection, water cooled diesel engine. Piston displacement. . . . 7,545 cm <sup>3</sup> Bore x stroke. . . . . 118 mm x 115 mm Max. output. . . . . 200 kW at 2,600 min <sup>-1</sup> {rpm} Max. torque. . . . . 785 N·m at 1,400 min <sup>-1</sup> {rpm}
<u>TRANSMISSION</u>	Electronically controlled full automatic transmission. Torque converter driving full powershift with driving axle selector. 6 forward and 2 reverse speeds. 3 speeds - High range - 2 wheel drive ; 4 wheel drive 3 speeds - Low range - 4 wheel drive
<u>AXLES</u>	Front. . . . Full floating type, steering and driving axle with planetary reduction. Rear. . . . Full floating type, steering and driving axle with planetary reduction. Non-spin differential.
<u>STEERING</u>	Hydraulic power steering controlled by steering wheel. Four steering modes available: 2-wheel front 2-wheel rear 4-wheel coordinated 4-wheel crab
<u>SUSPENSION</u>	Front. . . . Rigid mounted to the frame. Rear. . . . Pivot mounted with hydraulic lockout cylinders.
<u>BRAKE SYSTEM</u>	Service. . . Air over hydraulic disc brakes on all 4 wheels. Parking / Emergency. . . Spring applied-air released brake acting on input shaft of front axle. Auxiliary. . . Electro-pneumatic operated exhaust brake.
<u>ELECTRIC SYSTEM</u>	24 V DC. 2 batteries of 12 V - 120 Ah capacity.
<u>FUEL TANK CAPACITY</u>	300 liters
<u>TIRES</u>	Front. . . . 29.5 - 25 34PR(OR), Single x 2 Air pressure:400kPa Rear. . . . 29.5 - 25 34PR(OR), Single x 2 Air pressure:400kPa
<u>TURN RADIUS</u>	Min. turning radius (at center of extreme outer tire) 2-wheel steering. . . . . 11.9 m 4-wheel steering. . . . . 6.8 m

## EQUIPMENT

### STANDARD EQUIPMENT

Pendant type over-winding cutout  
 External lamp (AML)  
 Winch drum mirror  
 Slewing lock  
 Winch automatic fail-safe brake  
 Winch drum rotation indicator (Audible and Visual type)  
 2-speed hoist  
 Hook safety latch  
 Pilot check valves  
 Holding valves  
 Counterbalance valves  
 Hydraulic pressure relief valves  
 Slewing brake  
 Positive control  
 Hydraulic oil cooler  
 Hot water cab heater, air conditioner and defroster  
 Electric windshield wiper and washer  
 Roof window wiper and washer  
 Power window (Cab door)  
 Tachometer/Speedometer  
 3 way adjustable cloth seat with seat belt, headrest and armrest  
 Cab floor mat  
 Sun visor (Front and roof)  
 Tilt-telescope steering wheel  
 Boom elevation foot pedal  
 Boom telescoping foot pedal  
 Parking braked travel warning  
 Automatic moment limiter (AML)  
 Boom angle indicator  
 Outrigger extension width detector  
 Sight level gauge  
 Automatic drive system  
 Transmission neutral position engine start  
 Overshift prevention  
 Back-up alarm  
 Air cleaner dust indicator  
 Air dryer  
 Water separator with filter  
 Hydraulic lockout suspension  
 Non-spin differential (Rear)  
 Towing eyes - front and rear  
 Engine over-run alarm  
 Fuel consumption monitor  
 Eco mode system

### OPTIONAL EQUIPMENT

Over-unwinding prevention  
 Outrigger control box(Both side of carrier)  
 Cable follower  
 Emergency steering  
 Red warning lamp (Top boom)  
 Radiator cover  
 Tire inflation kit  
 Hook block – 80t capacity (7 sheaves, swivel type with safety latch.  
 Mass : approx. 700 kg)  
 Hook block – 60t capacity (6 sheaves, swivel type with safety latch.  
 Mass : approx. 540 kg)  
 Hook block - 50t capacity (5 sheaves, swivel type with safety latch.  
 Mass : approx. 500 kg)  
 Hook block - 35t capacity (3sheaves, swivel type with safety latch.  
 Mass : 450 kg)

## HOISTING PERFORMANCE

Layer	Main or auxiliary hoist 0.362 m drum 19 mm wire rope		
	Line pulls		drum grooved lagging
	Available <sup>1</sup>		Total wire rope
	Low	High	
N(kgf)	N(kgf)	Meters	
1st	89,100(9,090)	63,900(6,520)	34.2
2nd	80,700(8,230)	57,800(5,900)	71.5
3rd	73,700(7,520)	52,800(5,390)	111.8
4th	67,800(6,920)	48,600(4,960)	155.2
5th	62,800(6,410)	45,100(4,600)	201.6
6th	58,500(5,970)	41,900(4,280)	251.1
7th <sup>2</sup>	54,800(5,590)	39,300(4,010)	303.7

Maximum permissible line pull wire strength 64,700N(6,600 kg) with 7x35 class wire rope.

<sup>1</sup>Developed by machinery with each layer of wire rope, but not based on rope strength or other limitation in machinery or equipment.

<sup>2</sup>Seventh layer of wire rope are not recommended for hoisting operations.

# RATED LIFTING CAPACITIES

## ISO 4305

ON OUTRIGGERS FULLY EXTENDED 7.3 m SPREAD																				
360° ROTATION (Unit: x 1,000 kg)																				
B \ A	12 m		16.4 m		20.8 m				29.5 m				38.3 m				42.6 m		47 m	
	C		C		C	C		C		C		C		C		C		C		
3.0	70	80.0	75	46.6	79	40.9	78	18.2												
3.5	67	74.2	74	46.6	77	40.9	77	18.2												
4.0	64	67.0	72	46.6	76	40.9	76	18.2												
4.5	62	60.9	70	46.6	75	40.9	74	18.2												
5.0	59	55.7	68	46.6	73	38.9	73	18.2	79	18.2	78	15.1								
5.5	56	51.1	66	46.6	72	36.8	71	18.2	78	18.2	77	15.1								
6.0	53	46.2	64	45.8	70	34.9	70	18.2	77	18.2	76	15.1								
6.5	49	42.1	62	41.7	69	33.2	68	18.2	76	18.2	75	15.1								
7.0	46	38.6	60	38.3	67	31.6	67	18.2	75	18.2	75	15.1	79	15.1	79	13.0				
7.5	42	35.6	58	34.4	66	30.1	65	18.2	74	18.2	74	15.1	78	15.1	78	13.0				
8.0	38	33.0	56	31.0	64	28.1	64	18.2	73	18.2	73	15.1	78	15.1	78	12.8				
9.0	27	24.0	51	24.9	61	23.3	60	18.2	71	18.2	71	15.1	76	15.1	76	12.1	77	11.0		
10.0			46	20.2	58	19.7	57	18.2	69	18.2	69	15.0	75	14.6	75	11.3	76	11.0	79	9.5
11.0			40	16.7	54	16.3	54	18.2	67	16.6	66	14.0	74	13.8	73	10.7	75	10.7	77	9.5
12.0			34	14.0	50	13.6	50	16.4	65	14.6	64	13.2	72	13.0	72	10.1	73	10.2	76	9.5
14.0			13	10.2	42	9.9	42	12.4	60	11.2	60	11.7	69	11.3	68	9.0	71	9.3	74	9.3
16.0					32	7.3	32	9.8	55	8.6	55	10.3	65	9.1	65	8.1	68	8.5	72	8.6
18.0					16	5.5	16	7.5	50	6.7	50	8.3	62	7.2	62	7.4	65	7.7	69	7.5
20.0									44	5.3	44	6.9	58	5.8	58	6.8	62	6.6	66	6.2
22.0									38	4.2	38	5.7	54	4.7	54	5.9	59	5.4	63	5.0
24.0									30	3.3	30	4.8	50	3.8	50	5.0	56	4.5	60	4.1
26.0									20	2.5	20	4.0	46	3.0	46	4.2	52	3.8	57	3.4
28.0													41	2.4	41	3.6	48	3.1	54	2.8
30.0													36	1.9	36	3.1	44	2.6	50	2.2
32.0													29	1.5	30	2.6	40	2.2	47	1.8
34.0													22	1.1	22	2.2	35	1.8	43	1.4
36.0																	30	1.4	39	1.1
38.0																	23	1.1		
40.0																	12	0.9		
<b>D</b>	0																		22	
Telescoping conditions (%)																				
Telescoping mode	I, II	I	I	II	I	II	I	II	I	II	I	II	I	II	I	II	I, II			
2nd boom	0	50	100	0	100	0	100	0	100	0	100	0	100	0	50	100				
3rd boom	0	0	0	33	33	66	66	100	100	100	100	100	100	100	100	100				
4th boom	0	0	0	33	33	66	66	100	100	100	100	100	100	100	100	100				
Top boom	0	0	0	33	33	66	66	100	100	100	100	100	100	100	100	100				

LIFTING CAPACITIES AT ZERO DEGREE BOOM ANGLE ON OUTRIGGERS FULLY EXTENDED																				
7.3 m SPREAD 360° ROTATION																				
C \ A	12.0 m		16.4 m		20.8 m				29.5 m				38.3 m				42.6 m			
	B		B		B	B		B		B		B		B		B				
0°	9.8	20.3	14.1	10.0	18.4	5.2	18.4	7.2	27.2	2.2	27.0	3.7	35.8	0.8	35.0	2.1	40.0	0.9		
Telescoping mode	I, II		I		I		II		I		II		I		II		II			

- A : Boom length(m)
- B : Load radius(m)
- C : Loaded boom angle (°)
- D : Minimum boom angle (°) for indicated length (no load)



## RATED LIFTING CAPACITIES ISO 4305

ON OUTRIGGERS FULLY EXTENDED 7.3 m SPREAD 360° ROTATION														
C	47.0 m Boom + 10.1 m Jib								47.0 m Boom + 17.7 m Jib					
	3.5° Tilt		25° Tilt		45° Tilt				3.5° Tilt		25° Tilt		45° Tilt	
	R	W	R	W	R	W			R	W	R	W	R	W
80	10.9	4.9	14.2	4.9	16.7	4.3	80	12.8	3.1	19.1	2.9	23.8	2.3	
79	11.8	4.9	15.2	4.7	17.7	4.2	79	14.1	3.1	20.5	2.8	24.7	2.3	
78	12.9	4.9	16.4	4.6	18.6	4.1	78	15.5	3.1	21.7	2.7	26.0	2.3	
77	14.0	4.9	17.4	4.5	19.5	4.0	77	16.9	3.1	22.7	2.7	27.0	2.3	
76	15.1	4.9	18.4	4.4	20.5	3.9	76	18.1	3.1	24.1	2.6	28.0	2.2	
75	16.0	4.9	19.3	4.2	21.7	3.9	75	19.4	3.1	25.2	2.6	29.0	2.2	
73	18.2	4.8	21.3	4.0	23.5	3.7	73	21.9	3.1	27.3	2.5	30.0	2.2	
70	21.2	4.4	24.2	3.8	26.3	3.5	70	25.6	3.1	30.4	2.4	33.8	2.1	
68	23.2	4.1	26.0	3.6	28.0	3.4	68	27.8	3.0	32.4	2.3	35.7	2.1	
65	26.0	3.8	28.6	3.4	30.5	3.1	65	30.8	2.7	35.3	2.2	38.1	2.0	
63	27.8	3.2	30.2	2.9	31.9	2.7	63	32.7	2.3	36.9	2.0	39.6	1.8	
60	30.0	2.5	32.4	2.3	33.9	2.2	60	35.2	1.7	39.3	1.5	41.9	1.4	
58	31.7	2.1	34.0	2.0	35.2	1.9	58	36.7	1.4	40.8	1.3	43.0	1.2	
55	33.9	1.6	35.9	1.5	37.0	1.5	55	39.2	1.0	43.3	0.9			
53	35.3	1.4	37.2	1.3	38.4	1.2								
50	37.4	1.0	39.3	1.0	40.2	0.9								

ON OUTRIGGERS FULLY EXTENDED 7.3 m SPREAD 360° ROTATION														
C	42.6 m Boom(telescoping mode II) + 10.1 m Jib								42.6 m Boom(telescoping mode II) + 17.7 m Jib					
	3.5° Tilt		25° Tilt		45° Tilt				3.5° Tilt		25° Tilt		45° Tilt	
	R	W	R	W	R	W			R	W	R	W	R	W
80	9.4	5.3	13.4	5.2	15.6	4.6	80	11.5	3.3	18.5	3.0	22.6	2.4	
79	10.4	5.3	14.3	5.1	16.5	4.5	79	12.6	3.3	19.6	2.9	23.4	2.3	
78	11.3	5.3	15.3	5.0	17.5	4.4	78	13.8	3.3	20.4	2.8	24.5	2.3	
77	12.4	5.3	16.3	4.8	18.3	4.3	77	15.1	3.3	21.3	2.8	25.5	2.3	
76	13.5	5.3	17.2	4.7	19.2	4.2	76	16.3	3.3	22.3	2.7	26.4	2.3	
75	14.5	5.3	18.1	4.6	19.9	4.1	75	17.5	3.3	23.3	2.7	27.3	2.3	
73	16.5	5.2	19.8	4.3	21.6	4.0	73	19.6	3.3	25.4	2.6	28.9	2.2	
70	19.2	4.7	22.5	4.0	23.9	3.7	70	23.0	3.3	28.3	2.5	31.5	2.1	
68	21.1	4.5	24.1	3.9	25.5	3.6	68	25.2	3.3	30.1	2.4	33.1	2.1	
65	23.5	4.1	26.4	3.6	27.6	3.4	65	28.1	3.0	32.8	2.3	35.4	2.1	
63	25.2	3.9	28.0	3.5	29.1	3.3	63	30.2	2.9	34.6	2.3	36.9	2.0	
60	27.5	3.5	30.2	3.2	31.1	3.0	60	32.7	2.6	36.9	2.2	39.2	2.0	
58	28.9	3.1	31.6	2.9	32.4	2.7	58	34.3	2.2	38.4	2.0	40.4	1.9	
55	31.1	2.6	33.6	2.4	34.3	2.3	55	36.7	1.8	40.6	1.7	42.2	1.6	
53	32.5	2.3	34.8	2.1	35.3	2.0	53	38.0	1.6	41.7	1.4	43.4	1.4	
50	34.4	1.9	36.5	1.8	37.0	1.7	50	40.2	1.3	43.7	1.2	45.0	1.1	
48	35.7	1.7	37.7	1.6	38.1	1.5	48	41.6	1.1	45.0	1.0	46.0	1.0	
45	37.5	1.4	39.3	1.3	39.5	1.3								
43	38.6	1.2	40.4	1.1										
40	40.3	1.0	41.9	0.9										

ON OUTRIGGERS FULLY EXTENDED 7.3 m SPREAD 360° ROTATION														
C	38.3 m Boom(telescoping mode I) + 10.1 m Jib								38.3 m Boom(telescoping mode I) + 17.7 m Jib					
	3.5° Tilt		25° Tilt		45° Tilt				3.5° Tilt		25° Tilt		45° Tilt	
	R	W	R	W	R	W			R	W	R	W	R	W
80	8.4	6.6	12.5	6.4	14.7	4.9	80	10.5	4.0	17.1	3.2	20.8	2.4	
79	9.3	6.6	13.4	6.2	15.5	4.8	79	11.6	4.0	18.0	3.1	21.7	2.3	
78	10.3	6.6	14.1	6.0	16.3	4.7	78	12.7	4.0	19.0	3.0	22.6	2.3	
77	11.2	6.6	15.1	5.9	17.1	4.7	77	13.7	4.0	19.9	3.0	23.5	2.3	
76	12.1	6.6	15.8	5.7	18.0	4.6	76	14.8	4.0	20.7	2.9	24.4	2.3	
75	13.0	6.6	16.6	5.6	18.6	4.6	75	15.9	4.0	21.7	2.9	25.2	2.3	
73	14.9	6.6	18.2	5.4	20.1	4.5	73	18.0	4.0	23.5	2.8	26.8	2.2	
70	17.4	6.2	20.6	5.1	22.3	4.4	70	20.8	3.8	26.1	2.6	29.1	2.1	
68	19.0	5.9	22.1	4.9	23.6	4.4	68	22.7	3.6	27.8	2.6	30.7	2.1	
65	21.4	5.5	24.3	4.7	25.7	4.3	65	25.4	3.4	30.4	2.5	32.8	2.1	
63	22.8	4.8	25.6	4.3	26.9	3.9	63	27.3	3.2	31.9	2.4	34.2	2.1	
60	24.9	3.9	27.3	3.5	28.7	3.3	60	29.8	2.8	34.2	2.3	36.2	2.0	
58	26.2	3.4	28.6	3.1	29.8	2.9	58	31.2	2.4	35.5	2.1	37.5	2.0	
55	28.0	2.8	30.3	2.6	31.5	2.5	55	33.5	2.0	37.5	1.8	39.2	1.7	
53	29.5	2.5	31.5	2.3	32.6	2.2	53	34.9	1.7	38.6	1.5	40.4	1.5	
50	31.3	2.1	33.1	1.9	34.2	1.8	50	37.0	1.4	40.4	1.2	41.8	1.2	
48	32.5	1.8	34.2	1.7	35.1	1.6	48	38.3	1.2	41.6	1.1	42.7	1.0	
45	34.2	1.5	35.7	1.4	36.5	1.3	45	40.2	0.9					
43	35.3	1.3	36.7	1.2										
40	36.8	1.0	38.2	1.0										
38	37.7	0.9												

C :Loaded boom angle (°)  
R :Load radius(m)  
W :Rated lifting capacity(Unit: × 1,000kg)

## RATED LIFTING CAPACITIES ISO 4305

ON OUTRIGGERS MID EXTENDED 6.7 m SPREAD 360° ROTATION (Unit: x 1,000 kg)																				
B \ A	12 m		16.4 m		20.8 m			29.5 m			38.3 m			42.6 m		47 m				
	C		C		C		C		C		C		C		C		C			
3.0	70	80.0	76	46.6	79	40.9	78	18.2												
3.5	67	72.1	74	46.6	77	40.9	77	18.2												
4.0	65	65.0	72	46.6	76	40.9	76	18.2												
4.5	62	59.0	70	46.6	75	40.9	74	18.2												
5.0	59	53.8	68	46.6	73	38.9	73	18.2	79	18.2	78	15.1								
5.5	55	49.3	66	46.6	72	36.8	71	18.2	78	18.2	77	15.1								
6.0	52	44.0	64	43.5	70	34.5	70	18.2	77	18.2	76	15.1								
6.5	49	40.0	62	38.0	69	32.0	68	18.2	76	18.2	75	15.1								
7.0	46	35.5	60	33.6	67	30.0	67	18.2	75	18.2	74	15.1	79	15.1	79	13.0				
7.5	42	31.8	58	30.1	66	27.3	65	18.2	74	18.2	74	15.1	78	15.1	78	13.0				
8.0	37	27.8	55	27.1	64	24.6	64	18.2	73	18.2	73	15.1	78	15.1	78	12.8				
9.0	27	22.0	51	21.3	61	20.4	61	18.2	71	18.2	71	15.1	76	15.1	76	12.1	77	11.0		
10.0			46	17.2	57	16.8	57	18.2	69	17.0	69	15.0	75	14.6	75	11.3	76	11.0	79	9.5
11.0			40	14.2	54	13.8	54	16.7	67	14.7	66	14.0	73	13.8	73	10.7	75	10.7	78	9.5
12.0			34	11.9	50	11.5	50	14.2	64	12.9	64	13.2	72	12.6	72	10.1	73	10.2	77	9.5
14.0			13	8.6	42	8.2	42	10.8	60	9.6	60	11.3	69	10.0	68	9.0	70	9.3	74	9.3
16.0					32	6.0	32	8.4	55	7.3	55	8.9	65	7.9	65	8.1	68	8.3	71	8.0
18.0					16	4.3	15	6.7	50	5.6	50	7.2	62	6.2	62	7.2	65	6.9	69	6.5
20.0									44	4.3	44	5.9	58	4.9	58	6.1	62	5.6	66	5.2
22.0									38	3.3	38	4.8	54	3.9	54	5.1	59	4.6	63	4.2
24.0									30	2.5	31	4.0	50	3.1	50	4.2	56	3.8	60	3.4
26.0									20	1.9	20	3.4	46	2.4	46	3.5	52	3.1	57	2.7
28.0													41	1.8	41	3.0	48	2.5	53	2.1
30.0													36	1.4	36	2.5	44	2.0	50	1.7
32.0													30	1.0	29	2.1	40	1.6	46	1.3
34.0															21	1.7	35	1.3	43	0.9
36.0																	30	1.0		
<b>D</b>	0										6		0		23		34			
Telescoping conditions (%)																				
Telescoping mode	I, II		I		I		II		I		II		I		II		II		I, II	
2nd boom	0		50		100		0		100		0		100		0		50		100	
3rd boom	0		0		0		33		33		66		66		100		100		100	
4th boom	0		0		0		33		33		66		66		100		100		100	
Top boom	0		0		0		33		33		66		66		100		100		100	

LIFTING CAPACITIES AT ZERO DEGREE BOOM ANGLE ON OUTRIGGERS MID EXTENDED 6.7 m SPREAD 360° ROTATION																				
C \ A	12.0 m		16.4 m		20.8 m			29.5 m			38.3 m									
	B		B		B		B		B		B		B							
0°	9.8	18.0	14.2	8.3	18.5	4.0	18.3	6.5	27.2	1.5	27.2	3.0			35.4	1.6				
Telescoping mode	I, II		I		I		II		I		II		II							

- A : Boom length(m)
- B : Load radius(m)
- C : Loaded boom angle (°)
- D : Minimum boom angle (°) for indicated length (no load)

# RATED LIFTING CAPACITIES

## ISO 4305

ON OUTRIGGERS MID EXTENDED 6.7 m SPREAD							ON OUTRIGGERS MID EXTENDED 6.7 m SPREAD						
360° ROTATION							360° ROTATION						
C	47.0 m Boom + 10.1 m Jib						C	47.0 m Boom + 17.7 m Jib					
	3.5° Tilt		25° Tilt		45° Tilt			3.5° Tilt		25° Tilt		45° Tilt	
	R	W	R	W	R	W		R	W	R	W	R	W
80	10.8	4.9	14.3	4.9	16.7	4.3	80	12.8	3.1	19.1	2.9	23.8	2.3
79	11.9	4.9	15.4	4.7	17.8	4.2	79	14.1	3.1	20.5	2.8	24.7	2.3
78	13.0	4.9	16.4	4.6	18.8	4.1	78	15.5	3.1	21.6	2.7	26.1	2.3
77	14.1	4.9	17.6	4.5	19.8	4.0	77	16.9	3.1	22.9	2.7	27.2	2.3
76	15.2	4.9	18.5	4.4	20.8	3.9	76	18.1	3.1	24.2	2.6	28.1	2.2
75	16.1	4.9	19.6	4.2	21.9	3.9	75	19.4	3.1	25.4	2.6	29.2	2.2
73	18.3	4.8	21.5	4.0	23.6	3.7	73	21.9	3.1	27.5	2.5	31.1	2.2
70	21.2	4.4	24.3	3.8	26.4	3.5	70	25.6	3.1	30.5	2.4	33.9	2.1
68	23.1	3.9	26.0	3.5	28.0	3.2	68	27.6	2.7	32.5	2.3	35.7	2.1
65	25.7	3.0	28.2	2.7	30.2	2.5	65	30.2	2.0	35.0	1.8	37.9	1.7
63	27.4	2.5	29.9	2.3	31.6	2.2	63	32.3	1.7	36.4	1.5	39.3	1.4
60	29.9	1.9	32.3	1.8	33.8	1.7	60	34.6	1.2	38.9	1.1	41.4	1.0
58	31.4	1.6	33.8	1.5	35.1	1.4	58	36.4	1.0				
55	33.7	1.2	35.7	1.1	37.0	1.0							
53	35.1	0.9											

ON OUTRIGGERS MID EXTENDED 6.7 m SPREAD							ON OUTRIGGERS MID EXTENDED 6.7 m SPREAD						
360° ROTATION							360° ROTATION						
C	42.6 m Boom(telescoping mode II) + 10.1 m Jib						C	42.6 m Boom(telescoping mode II) + 17.7 m Jib					
	3.5° Tilt		25° Tilt		45° Tilt			3.5° Tilt		25° Tilt		45° Tilt	
	R	W	R	W	R	W		R	W	R	W	R	W
80	9.3	5.3	13.3	5.2	15.7	4.6	80	11.5	3.3	18.6	3.0	22.5	2.4
79	10.4	5.3	14.3	5.1	16.5	4.5	79	12.7	3.3	19.4	2.9	23.4	2.3
78	11.5	5.3	15.2	5.0	17.4	4.4	78	13.8	3.3	20.4	2.8	24.4	2.3
77	12.5	5.3	16.2	4.8	18.4	4.3	77	15.0	3.3	21.3	2.8	25.4	2.3
76	13.6	5.3	17.2	4.7	19.1	4.2	76	16.1	3.3	22.2	2.7	26.3	2.3
75	14.5	5.3	18.1	4.6	19.9	4.1	75	17.4	3.3	23.3	2.7	27.2	2.3
73	16.4	5.2	19.7	4.3	21.6	4.0	73	19.6	3.3	25.4	2.6	29.0	2.2
70	19.2	4.7	22.3	4.0	23.9	3.7	70	23.0	3.3	28.2	2.5	31.4	2.1
68	21.1	4.5	24.0	3.9	25.5	3.6	68	25.3	3.3	30.3	2.4	33.1	2.1
65	23.5	4.1	26.4	3.6	27.6	3.4	65	28.1	3.0	32.7	2.3	35.3	2.1
63	25.1	3.7	27.9	3.3	28.9	3.1	63	29.8	2.7	34.7	2.2	36.8	2.0
60	27.2	3.0	29.9	2.7	30.9	2.6	60	32.1	2.1	36.5	1.8	38.8	1.7
58	28.7	2.6	31.3	2.4	32.2	2.3	58	33.8	1.8	38.0	1.6	40.1	1.5
55	30.7	2.1	33.2	1.9	34.0	1.9	55	36.2	1.4	40.0	1.2	42.0	1.2
53	32.1	1.8	34.5	1.7	35.1	1.6	53	37.7	1.2	41.4	1.1	43.1	1.0
50	34.1	1.5	36.3	1.4	36.8	1.3	50	39.8	0.9				
48	35.4	1.3	37.4	1.2	37.9	1.2							
45	37.2	1.0	39.2	1.0	39.4	0.9							

ON OUTRIGGERS MID EXTENDED 6.7 m SPREAD							ON OUTRIGGERS MID EXTENDED 6.7 m SPREAD						
360° ROTATION							360° ROTATION						
C	38.3 m Boom(telescoping mode I) + 10.1 m Jib						C	38.3 m Boom(telescoping mode I) + 17.7 m Jib					
	3.5° Tilt		25° Tilt		45° Tilt			3.5° Tilt		25° Tilt		45° Tilt	
	R	W	R	W	R	W		R	W	R	W	R	W
80	8.4	6.6	12.5	6.4	14.7	4.9	80	10.5	4.0	17.0	3.2	20.8	2.4
79	9.3	6.6	13.2	6.2	15.5	4.8	79	11.6	4.0	18.1	3.1	21.7	2.3
78	10.3	6.6	14.1	6.0	16.2	4.7	78	12.7	4.0	18.9	3.0	22.7	2.3
77	11.2	6.6	15.0	5.9	17.1	4.7	77	13.7	4.0	19.9	3.0	23.5	2.3
76	12.2	6.6	15.8	5.7	17.8	4.6	76	14.8	4.0	20.8	2.9	24.4	2.3
75	13.0	6.6	16.6	5.6	18.6	4.6	75	15.9	4.0	21.8	2.9	25.3	2.3
73	14.9	6.6	18.2	5.4	20.0	4.5	73	17.8	4.0	23.5	2.8	26.7	2.2
70	17.4	6.2	20.6	5.1	22.3	4.4	70	20.8	3.8	26.2	2.6	29.3	2.1
68	19.1	5.9	22.1	4.9	23.7	4.4	68	22.7	3.6	28.0	2.6	30.7	2.1
65	21.2	4.8	24.0	4.1	25.6	3.8	65	25.6	3.4	30.4	2.5	32.8	2.1
63	22.6	4.2	25.3	3.6	26.8	3.4	63	27.2	3.0	32.1	2.4	34.4	2.1
60	24.7	3.4	27.0	2.9	28.5	2.8	60	29.4	2.3	34.0	2.0	36.2	1.9
58	26.1	2.9	28.3	2.5	29.7	2.4	58	30.9	2.0	35.4	1.7	38.4	1.6
55	28.0	2.4	30.1	2.1	31.4	2.0	55	33.3	1.6	37.3	1.4	39.1	1.3
53	29.3	2.0	31.3	1.8	32.5	1.8	53	34.7	1.3	38.5	1.1	40.2	1.1
50	31.1	1.6	33.0	1.5	34.1	1.4	50	36.8	1.0				
48	32.3	1.4	34.1	1.3	35.0	1.2							
45	34.0	1.1	35.6	1.0	36.4	1.0							
43	35.1	0.9											

C :Loaded boom angle (°)  
R :Load radius(m)  
W :Rated lifting capacity(Unit:x1,000kg)

# RATED LIFTING CAPACITIES

## ISO 4305

ON OUTRIGGERS MID EXTENDED 5.5 m SPREAD																				
360° ROTATION (Unit: x 1,000 kg)																				
B \ A	12 m		16.4 m		20.8 m				29.5 m				38.3 m				42.6 m		47 m	
	C		C		C	C		C	C		C	C		C	C		C	C		
3.0	70	75.4	75	46.6	79	40.9	78	18.2												
3.5	67	67.0	74	46.6	77	40.9	77	18.2												
4.0	64	60.1	72	46.6	76	40.9	76	18.2												
4.5	61	52.8	70	46.6	75	40.9	74	18.2												
5.0	58	47.2	68	41.1	73	36.5	73	18.2	79	18.2	78	15.1								
5.5	55	40.3	66	35.4	72	31.6	71	18.2	78	18.2	77	15.1								
6.0	52	35.0	64	30.9	70	27.8	70	18.2	77	18.2	76	15.1								
6.5	49	30.1	62	27.3	69	24.6	68	18.2	76	18.2	75	15.1								
7.0	45	25.9	60	24.3	67	22.0	67	18.2	75	18.2	74	15.1	79	15.1	79	13.0				
7.5	42	22.6	58	21.9	66	19.8	65	18.2	74	18.2	74	15.1	78	15.1	78	13.0				
8.0	38	19.9	55	19.4	64	17.9	64	18.2	73	17.4	73	15.1	78	15.1	78	12.8				
9.0	27	15.9	51	15.3	61	14.8	61	16.7	71	14.8	71	15.1	76	14.1	76	12.1	77	11.0		
10.0			46	12.4	57	12.0	57	14.8	69	12.6	69	14.6	75	12.2	75	11.3	76	11.0	79	9.5
11.0			40	10.2	54	9.8	54	12.5	66	10.9	66	12.8	73	10.7	73	10.7	75	10.7	77	9.5
12.0			34	8.5	50	8.1	50	10.6	64	9.5	64	11.2	71	9.4	71	10.1	73	9.9	76	9.1
14.0			13	5.9	42	5.5	42	8.0	60	6.9	59	8.5	68	7.4	68	8.8	71	8.0	74	7.3
16.0					32	3.8	32	6.2	55	5.1	55	6.7	65	5.7	65	6.9	68	6.4	71	5.9
18.0					16	2.5	14	4.8	49	3.7	50	5.3	61	4.3	61	5.5	65	5.0	68	4.7
20.0									44	2.7	44	4.2	57	3.3	58	4.4	62	4.0	65	3.6
22.0									38	1.9	38	3.4	54	2.5	54	3.6	59	3.2	62	2.8
24.0									30	1.3	30	2.7	50	1.8	50	2.9	55	2.5	59	2.1
26.0											20	2.2	45	1.3	45	2.4	52	1.9	56	1.6
28.0															40	1.9	48	1.5	53	1.1
30.0															35	1.5	44	1.1		
32.0															29	1.2				
34.0															20	0.9				
<b>D</b>	0										35		0		29		38			
Telescoping conditions (%)																				
Telescoping mode	I, II		I		I		II		I		II		I		II		II		I, II	
2nd boom	0		50		100		0		100		0		100		0		50		100	
3rd boom	0		0		0		33		33		66		66		100		100		100	
4th boom	0		0		0		33		33		66		66		100		100		100	
Top boom	0		0		0		33		33		66		66		100		100		100	

LIFTING CAPACITIES AT ZERO DEGREE BOOM ANGLE ON OUTRIGGERS MID EXTENDED																				
5.5 m SPREAD 360° ROTATION																				
C \ A	12.0 m		16.4 m		20.8 m				29.5 m				38.3 m							
	B		B		B	B		B	B		B	B		B	B		B	B		
0°	9.8	13.0	14.1	5.8	18.5	2.3	18.3	4.6	27.2	0.5	27.1	2.0			35.4	0.4				
Telescoping mode	I, II		I		I		II		I		II				II					

- A : Boom length(m)
- B : Load radius(m)
- C : Loaded boom angle (°)
- D : Minimum boom angle (°) for indicated length (no load)

# RATED LIFTING CAPACITIES

## ISO 4305

ON OUTRIGGERS MID EXTENDED 5.5 m SPREAD							ON OUTRIGGERS MID EXTENDED 5.5 m SPREAD						
360° ROTATION							360° ROTATION						
C	47.0 m Boom + 10.1 m Jib						C	47.0 m Boom + 17.7 m Jib					
	3.5° Tilt		25° Tilt		45° Tilt			3.5° Tilt		25° Tilt		45° Tilt	
	R	W	R	W	R	W		R	W	R	W	R	W
80	10.7	4.9	14.2	4.9	16.8	4.3	80	12.8	3.1	19.3	2.9	23.9	2.3
79	11.9	4.9	15.4	4.7	17.8	4.2	79	14.1	3.1	20.5	2.8	24.9	2.3
78	13.0	4.9	16.5	4.6	18.8	4.1	78	15.6	3.1	21.7	2.7	26.0	2.3
77	14.0	4.9	17.6	4.5	19.8	4.0	77	16.9	3.1	22.9	2.7	27.1	2.3
76	15.2	4.9	18.6	4.4	20.8	3.9	76	18.2	3.1	24.0	2.6	28.2	2.2
75	16.3	4.9	19.5	4.2	21.9	3.9	75	19.5	3.1	23.1	2.6	29.1	2.2
73	18.3	4.2	21.5	3.5	23.6	3.3	73	22.2	2.8	27.5	2.3	31.2	2.2
70	21.2	3.1	24.2	2.7	26.4	2.5	70	25.8	2.0	30.7	1.7	33.9	1.6
68	23.2	2.5	26.1	2.2	28.0	2.1	68	27.9	1.6	32.5	1.4	35.8	1.3
65	26.1	1.8	28.7	1.6	30.5	1.6	65	31.2	1.1	35.4	0.9	38.2	0.9
63	27.8	1.5	30.2	1.3	32.0	1.3							
60	30.1	1.0											

ON OUTRIGGERS MID EXTENDED 5.5m SPREAD							ON OUTRIGGERS MID EXTENDED 5.5m SPREAD						
360° ROTATION							360° ROTATION						
C	42.6 m Boom(telescoping mode II) + 10.1 m Jib						C	42.6 m Boom(telescoping mode II) + 17.7 m Jib					
	3.5° Tilt		25° Tilt		45° Tilt			3.5° Tilt		25° Tilt		45° Tilt	
	R	W	R	W	R	W		R	W	R	W	R	W
80	9.3	5.3	13.4	5.2	15.7	4.6	80	11.5	3.3	18.6	3.0	22.5	2.4
79	10.4	5.3	14.3	5.1	16.6	4.5	79	12.7	3.3	19.6	2.9	23.5	2.3
78	11.4	5.3	15.2	5.0	17.4	4.4	78	13.9	3.3	20.2	2.8	24.4	2.3
77	12.4	5.3	16.2	4.8	18.3	4.3	77	15.0	3.3	21.2	2.8	25.3	2.3
76	13.6	5.3	17.2	4.7	19.1	4.2	76	16.2	3.3	22.3	2.7	26.3	2.3
75	14.5	5.3	18.1	4.6	20.0	4.1	75	17.5	3.3	23.1	2.7	27.3	2.3
73	16.5	5.2	19.8	4.3	21.6	4.0	73	19.7	3.3	25.9	2.6	29.0	2.2
70	19.2	4.5	22.3	3.9	23.9	3.6	70	23.0	3.2	28.2	2.5	31.5	2.1
68	20.7	3.8	23.8	3.3	25.2	3.1	68	24.7	2.6	29.9	2.3	33.0	2.0
65	23.0	3.0	26.0	2.6	27.2	2.4	65	27.4	2.0	32.4	1.8	35.0	1.5
63	24.5	2.5	27.3	2.2	28.5	2.1	63	29.1	1.7	33.8	1.5	36.4	1.3
60	26.7	1.9	29.5	1.7	30.5	1.6	60	31.6	1.3	36.0	1.1	38.5	1.0
58	28.1	1.6	30.8	1.5	31.8	1.4							
55	30.3	1.2	32.8	1.1	33.7	1.1	58	33.2	1.0				
53	31.7	1.0											

ON OUTRIGGERS MID EXTENDED 5.5 m SPREAD							ON OUTRIGGERS MID EXTENDED 5.5 m SPREAD						
360° ROTATION							360° ROTATION						
C	38.3 m Boom(telescoping mode I) + 10.1 m Jib						C	38.3 m Boom(telescoping mode I) + 17.7 m Jib					
	3.5° Tilt		25° Tilt		45° Tilt			3.5° Tilt		25° Tilt		45° Tilt	
	R	W	R	W	R	W		R	W	R	W	R	W
80	8.4	6.6	12.5	6.4	14.7	4.9	80	10.5	4.0	17.0	3.2	20.8	2.4
79	9.3	6.6	13.4	6.2	15.5	4.8	79	11.6	4.0	18.1	3.1	21.7	2.3
78	10.3	6.6	14.2	6.0	16.3	4.7	78	12.7	4.0	19.0	3.0	22.7	2.3
77	11.2	6.6	15.0	5.9	17.1	4.7	77	13.8	4.0	19.9	3.0	23.6	2.3
76	12.2	6.6	15.9	5.7	17.9	4.6	76	14.8	4.0	20.8	2.9	24.5	2.3
75	13.0	6.6	16.6	5.6	18.7	4.6	75	15.9	4.0	21.8	2.9	25.3	2.3
73	14.8	6.3	18.3	5.4	20.1	4.5	73	18.0	4.0	23.6	2.8	26.9	2.2
70	17.1	5.0	20.3	4.3	22.2	3.9	70	20.7	3.7	26.3	2.6	29.2	2.1
68	18.6	4.2	21.7	3.7	23.4	3.4	68	22.5	3.1	28.0	2.5	30.8	2.1
65	20.8	3.3	23.6	2.9	25.3	2.7	65	25.0	2.4	30.1	1.9	32.8	1.8
63	22.3	2.8	24.9	2.5	26.5	2.3	63	26.6	1.9	31.5	1.6	34.0	1.5
60	24.4	2.1	26.8	1.9	28.3	1.8	60	28.9	1.4	33.7	1.2	35.9	1.1
58	25.8	1.8	28.1	1.6	29.5	1.5	58	30.5	1.1	35.1	1.0	37.1	0.9
55	27.8	1.3	29.9	1.2	31.3	1.1							
53	28.9	1.0	31.0	1.0	32.3	0.9							

C : Loaded boom angle (°)  
 R : Load radius(m)  
 W : Rated lifting capacity(Unit:x1,000kg)

# RATED LIFTING CAPACITIES

## ISO 4305

ON OUTRIGGERS MIN EXTENDED 2.7 m SPREAD																		
360° ROTATION (Unit: x 1,000 kg)																		
B \ A	12 m		16.4 m		20.8 m			29.5 m			38.3 m			42.6 m		47 m		
	C		C		C	C		C	C		C	C		C	C	C	C	
3.0	70	33.8	75	28.9	79	20.9	78	18.2										
3.5	67	27.7	74	23.9	78	20.9	77	18.2										
4.0	64	23.3	71	20.2	76	17.8	75	18.2										
4.5	61	19.9	70	17.3	75	15.3	74	18.2										
5.0	58	17.2	68	15.0	73	13.2	73	16.1	78	12.7	78	14.6						
5.5	55	14.5	66	13.0	72	11.5	71	14.4	77	11.3	77	13.1						
6.0	52	12.3	64	11.5	70	10.1	70	12.9	76	10.1	76	11.9						
6.5	48	10.6	62	10.1	68	8.9	68	11.6	75	9.0	75	10.8						
7.0	45	9.2	60	8.7	67	7.8	67	10.5	74	8.1	74	9.9	78	7.8	79	8.5		
7.5	42	8.0	57	7.5	66	6.9	65	9.6	73	7.3	73	9.1	77	7.1	78	8.5		
8.0	38	7.0	55	6.5	64	6.1	63	8.7	72	6.6	72	8.3	77	6.5	77	7.8		
9.0	28	5.4	50	4.9	61	4.6	60	7.0	70	5.4	70	7.1	75	5.4	76	6.7	77	
10.0			46	3.7	57	3.3	57	5.7	68	4.4	68	6.1	74	4.5	74	5.8	76	
11.0			40	2.7	54	2.3	53	4.6	66	3.6	66	5.1	72	3.8	72	5.0	74	
12.0			34	1.9	50	1.5	49	3.8	63	2.8	63	4.3	71	3.1	71	4.4	73	
14.0							41	2.5	59	1.6	59	3.0	67	2.0	68	3.2	70	
16.0							32	1.6			54	2.1	64	1.1	64	2.3	67	
18.0							12	0.9			49	1.4			61	1.6	64	
20.0															57	1.0		
<b>D</b>	0		12		42		0		54		43		60		53		58	63
Telescoping conditions (%)																		
Telescoping mode	I, II		I		I		II		I		II		I		II		II	
2nd boom	0		50		100		0		100		0		100		0		50	
3rd boom	0		0		0		33		33		66		66		100		100	
4th boom	0		0		0		33		33		66		66		100		100	
Top boom	0		0		0		33		33		66		66		100		100	

LIFTING CAPACITIES AT ZERO DEGREE BOOM ANGLE ON OUTRIGGERS MIN EXTENDED												
2.7 m SPREAD 360° ROTATION												
C \ A	12.0 m				20.8 m							
	B				B							
0°	9.8	4.0			18.3	0.8						
Telescoping mode	I, II				II							

- A : Boom length(m)
- B : Load radius(m)
- C : Loaded boom angle (°)
- D : Minimum boom angle (°) for indicated length (no load)

NOTES FOR "ON OUTRIGGERS" TABLE

1. Rated lifting capacities shown in the table are based on condition that crane is set on firm level surface. Those above thick lines are based on crane strength and those below, on its stability.
2. Rated lifting capacities based on crane stability are according to ISO4305.
3. The mass of the hook (700 kg for 80t capacity, 540 kg for 60t capacity, 500 kg for 50t capacity, 450 kg for 35t capacity, 165 kg for 6.6t capacity), slings and all similarly used load handling devices must be considered as part of the load and must be deducted from the lifting capacities.
4. For rated lifting capacity of single top, reduce the rated lifting capacities of relevant boom according to a weight reduction for auxiliary load handling equipment. Capacities of single top shall not exceed 6,600 kg including main boom hook mass and the net capacity must be so reduced.
5. Standard number of parts of line for each boom length is as shown below. Load per line should not surpass 64.7 kN {6,600 kgf} for main winch and auxiliary winch.

Boom length	12.0 m	12.0 m to 20.8 m		20.8 m to 47.0 m	Single top Jib
Telescoping mode	I, II	I	II	I, II	I, II
Number of parts of line	14	8	4	4	1

The lifting capacity data stored in the AUTOMATIC MOMENT LIMITER (AML) is based on the standard number of parts of line listed in the chart.

Maximum lifting capacity is restricted by the number of parts of line of AUTOMATIC MOMENT LIMITER (AML).

6. The lifting capacity for over-side area differs depending on the outrigger extension width. Work with the capacity corresponding to the extension width. The lifting capacities for over-front and over-rear areas are for "outriggers fully extended". However, the areas (angle **a**) differ depending on the outrigger extension width.

Outriggers extended width	6.7 m (middle)	5.5 m (middle)	2.7 m (minimum)
Angle <b>a</b> °	60	40	15

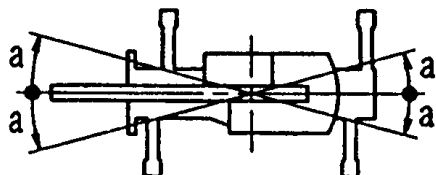

## RATED LIFTING CAPACITIES ISO 4305

ON-RUBBER STATIONARY (Unit: x 1,000 kg)													
A	Over Front						360° Rotation						
	12 m		20.8 m		29.5 m		12 m		20.8 m		29.5 m		
B	C		C		C		C		C		C		
3.5	67	28.5											
4.0	64	25.3					64	15.5					
4.5	61	23.0					61	12.9					
5.0	58	20.9					58	10.9					
5.5	55	19.0					55	9.3					
6.0	52	17.3	70	13.5			52	7.9	70	9.0			
6.5	49	15.9	68	13.5			49	6.6	68	7.8			
7.0	45	14.7	67	13.5	74	10.4	45	5.6	67	6.8			
7.5	42	13.3	65	13.5	73	10.4	42	4.7	65	6.0	73	6.8	
8.0	38	12.2	63	12.6	72	10.4	38	3.8	63	5.2	72	6.0	
8.5	33	11.0	62	11.7	71	10.0	33	3.3	62	4.7	71	5.2	
9.0	28	10.0	60	10.8	70	9.8	28	2.8	60	4.2	70	4.6	
10.0			57	9.0	68	9.3			57	3.3	68	3.5	
11.0			53	7.6	66	8.3			53	2.5	66	2.8	
12.0			50	6.5	64	7.2			50	2.0	63	2.2	
14.0			42	4.8	59	5.3			42	1.0	59	1.5	
16.0			32	3.5	54	4.1							
18.0			13	2.5	49	3.2							
20.0					44	2.5							
22.0					37	1.8							
24.0					30	1.2							
26.0					19	0.9							
<b>D</b>	0						31						54
Telescoping conditions (%)													
Telescoping mode	I, II		II		II		I, II		II		II		
2nd boom	0		0		0		0		0		0		
3rd boom	0		33		66		0		33		66		
4th boom	0		33		66		0		33		66		
Top boom	0		33		66		0		33		66		
LIFTING CAPACITIES AT ZERO DEGREE BOOM ANGLE ON-RUBBER STATIONARY													
A	Over Front						360°Rotation						
	12 m		20.8 m		29.5 m		12 m		20.8 m		29.5 m		
C	B		B		B		B		B		B		
0	9.9	8.5	18.3	2.4	27.2	0.6	9.9	2.0					

ON-RUBBER CREEP (Unit: x 1,000 kg)													
A	Over Front						360° Rotation						
	12 m		20.8 m		29.5 m		12 m		20.8 m		29.5 m		
B	C		C		C		C		C		C		
4.0	65	19.0					64	11.2					
4.5	61	17.0					62	9.8					
5.0	58	15.1					58	8.5					
5.5	55	13.6					55	7.5					
6.0	52	12.4	70	13.5			52	6.5	69	7.5			
6.5	49	11.4	68	12.3			49	5.4	68	6.5			
7.0	45	10.3	66	11.4	74	10.4	45	4.7	67	5.8			
7.5	42	9.5	65	10.5	73	10.4	42	3.8	65	5.0	73	5.8	
8.0	39	8.7	64	9.7	72	10.0	38	3.1	63	4.3	72	5.0	
8.5	33	8.0	62	9.1	71	9.4	34	2.5	62	3.8	71	4.3	
9.0	27	7.3	60	8.5	70	8.7	28	2.3	60	3.3	70	3.8	
10.0			57	7.3	68	7.7			57	2.5	69	3.0	
11.0			53	6.3	66	6.7			53	2.0	68	2.5	
12.0			50	5.6	64	6.0			50	1.5	66	1.9	
14.0			42	4.2	59	4.7					59	1.1	
16.0			32	3.3	54	3.7							
18.0			13	2.5	49	2.6							
20.0					43	2.0							
22.0					37	1.4							
24.0					30	1.0							
<b>D</b>	0						19						0
<b>D</b>	0						38						54
Telescoping conditions (%)													
Telescoping mode	I, II		II		II		I, II		II		II		
2nd boom	0		0		0		0		0		0		
3rd boom	0		33		66		0		33		66		
4th boom	0		33		66		0		33		66		
Top boom	0		33		66		0		33		66		
LIFTING CAPACITIES AT ZERO DEGREE BOOM ANGLE ON-RUBBER STATIONARY													
A	Over Front						360°Rotation						
	12 m		20.8 m		29.5 m		12 m		20.8 m		29.5 m		
C	B		B		B		B		B		B		
0	9.9	6.3	18.3	2.4			9.9	1.6					

A : Boom length(m)  
 B : Load radius(m)  
 C : Loaded boom angle (°)  
 D : Minimum boom angle (°) for indicated length (no load)



NOTES FOR "ON-RUBBER" TABLES

1. Rated lifting capacities shown in the table are based on condition that crane is set on firm level surface, with suspension lock applied. Those above thick lines are based on tire capacity and those below, on crane stability. They are based on actual load radius increased by tire deformation and boom deflection.
2. Rated lifting capacities based on crane stability are according to ISO4305.
3. The mass of the hook (700 kg for 80t capacity, 540 kg for 60t capacity, 500 kg for 50t capacity, 450 kg for 35t capacity, 165 kg for 6.6t capacity), slings and all similarly used load handling devices must be considered as part of the load and must be deducted from the lifting capacities.
4. For rated lifting capacity of single top, reduce the rated lifting capacities of relevant boom according to weight reductions for auxiliary load handling equipment. Capacities of single top shall not exceed 6,600 kg including main hook.
5. On-rubber lifting with "jib" is not permitted. Maximum permissible boom length is 29.5 m (over front).
6. CREEP is motion for crane not to travel more than 60 m in any 30 minute period and to travel at the speed of less than 1.6 km/h.
7. During "CREEP" duties travel slowly and keep the lifting load as close to the ground as possible, and especially avoid any abrupt steering, accelerating or braking.
8. Do not operate the crane while carrying the load.
9. Tires should be inflated to their correct air pressure of 400kPa.
10. For CREEP operation, choose the drive mode and proper gear according to the road or working condition.
11. Standard number of parts of line for on-rubber operation should be according to the following table.  
Load per line should not surpass 64.7 kN {6,600 kgf} for main winch and auxiliary winch.

Boom length	12.0 m	12.0 m to 29.5 m	Single top
Telescoping mode	I, II	II	I, II
Number of parts of line	6	4	1

The lifting capacity data stored in the AUTOMATIC MOMENT LIMITER (AML) is based on the standard number of parts of line listed in the chart.

Maximum lifting capacity is restricted by the number of parts of line of AUTOMATIC MOMENT LIMITER (AML).

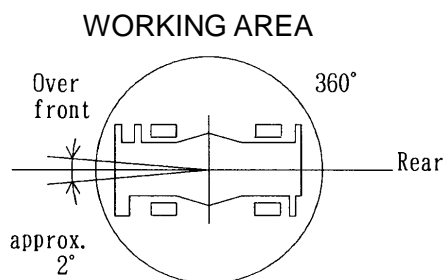

Without outriggers "Over front" operation should be performed within 2 degrees in front of chassis.

# WORKING RANGE CHART

Telescoping mode I

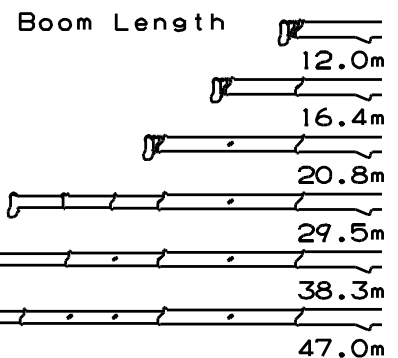
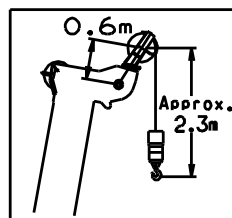
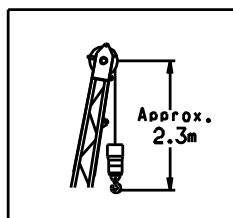
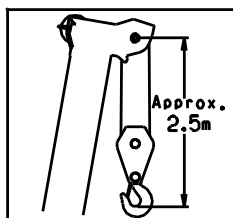
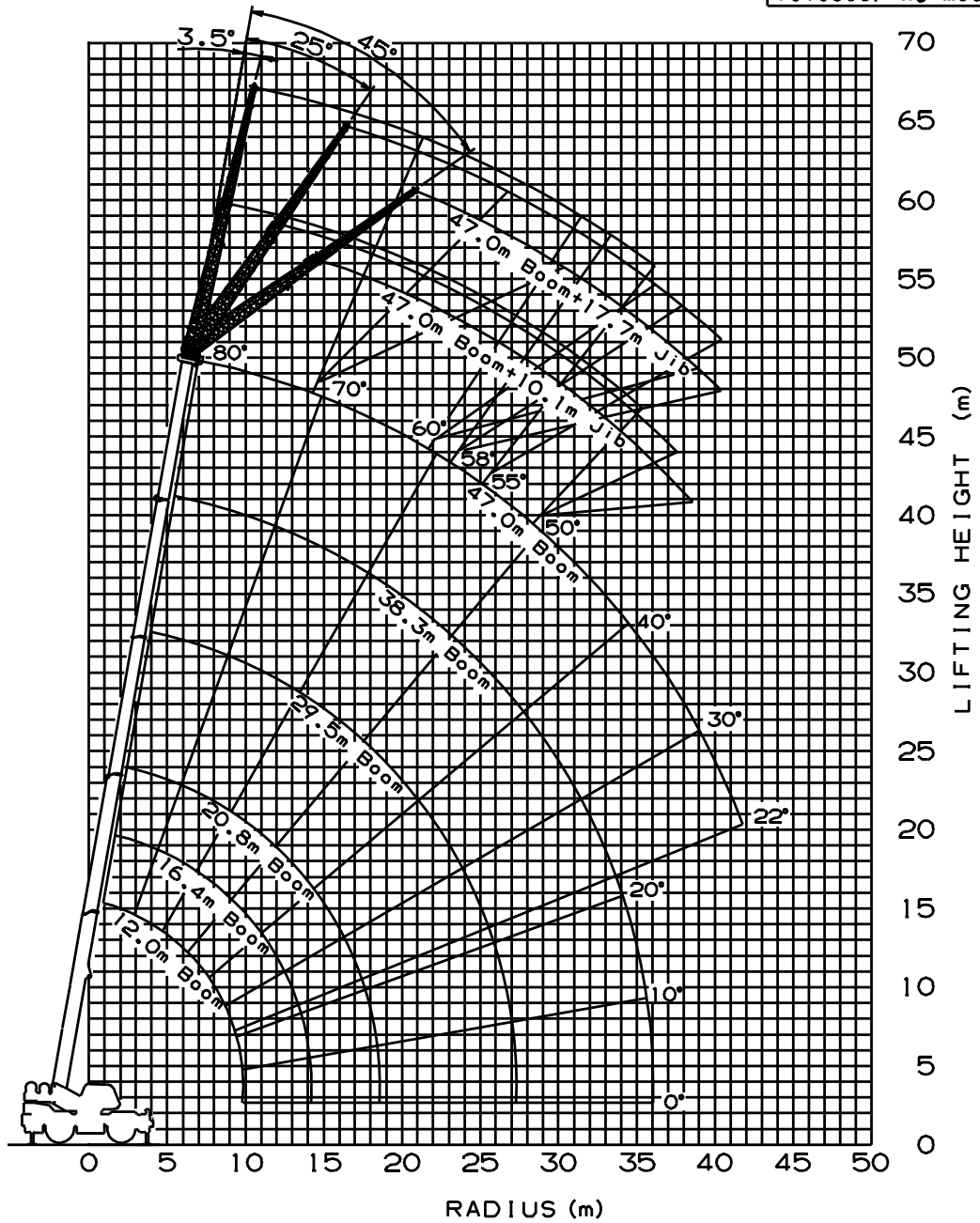

NOTE: 1. Boom and jib geometry shown are for unloaded condition and machine standing level on firm supporting surface. Boom deflection and subsequent radius and boom angle change must be accounted for when applying load to hook.

# WORKING RANGE CHART

Telescoping mode I

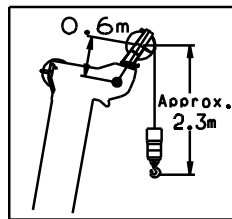
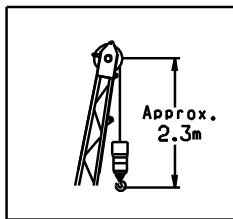
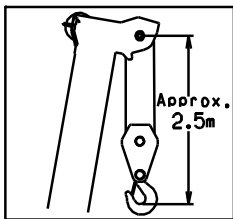
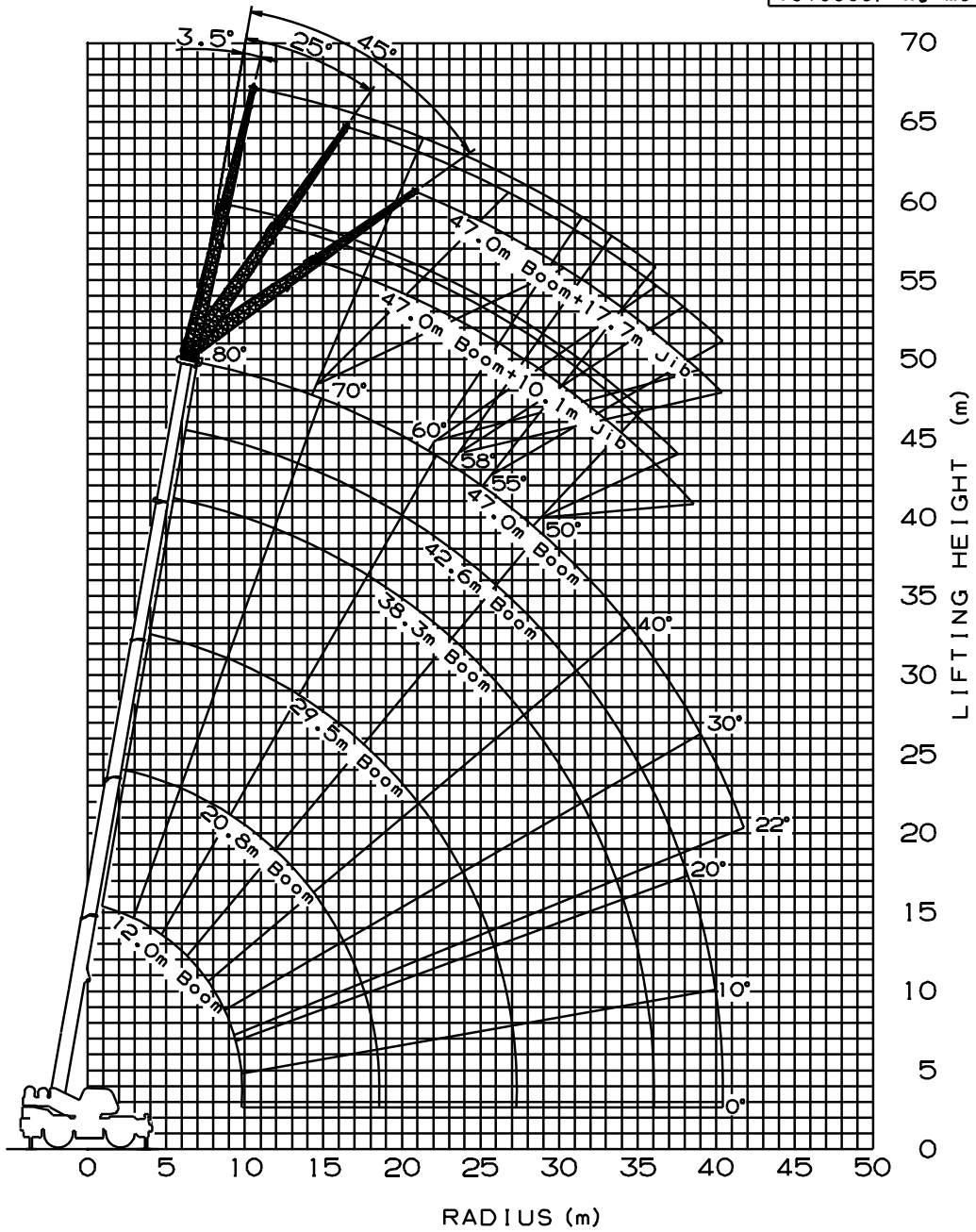

Boom Length

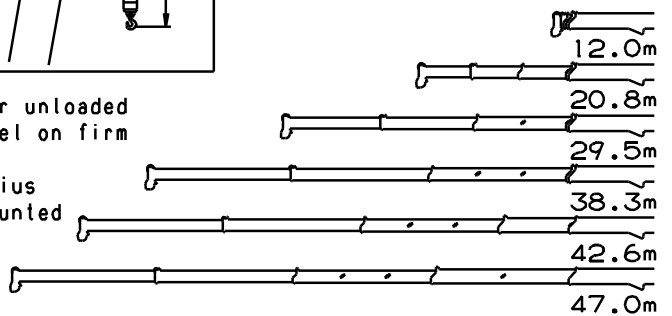

NOTE: 1. Boom and jib geometry shown are for unloaded condition and machine standing level on firm supporting surface.  
Boom deflection and subsequent radius and boom angle change must be accounted for when applying load to hook.

**DIMENSIONS**

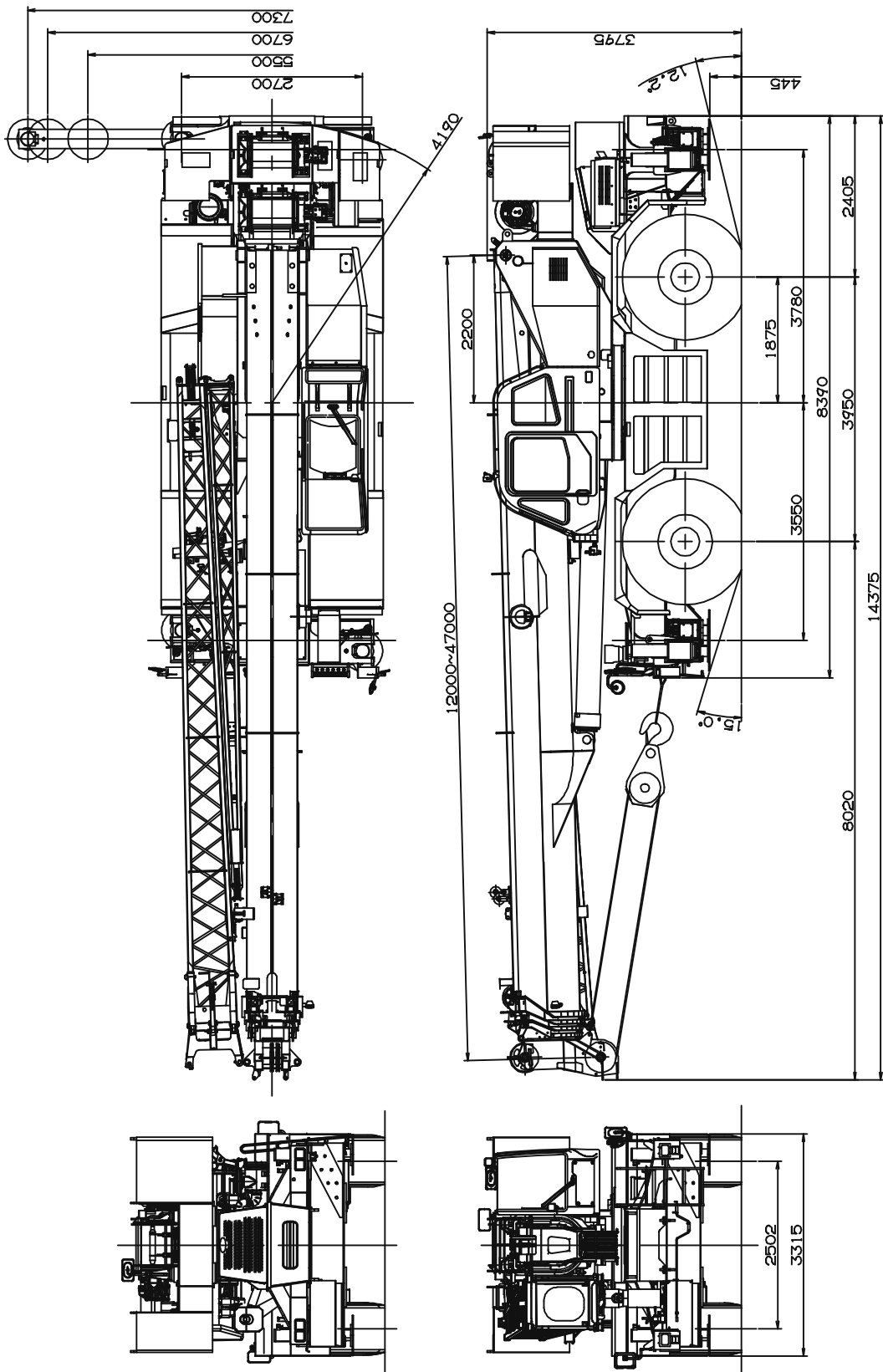

## GR-800EX Axle Weight Distribution Chart

UNIT : kg

	GVW	Front	Rear
Basic standard machine includes: 5-section boom (12.0 m - 47.0 m) 2-stage jib (10.1 m, 17.7 m) Mitsubishi 6M60-TLC1B 29.5 - 25 34PR tires Single top 6.6 ton hook ball	51,410	24,325	27,085
Add:			
1. 80t 7 sheaves hook block	+700	+1,350	-650
2. 60t 6 sheaves hook block	+540	+1,040	-500
3. 50t 5 sheaves hook block	+500	+970	-470
4. 35t 3 sheaves hook block	+450	+870	-420
Remove:			
1. 6.6 ton hook ball	-165	-235	70
2. Top jib	-335	-450	+115
3. Base jib	-865	-1,705	+840
4. Counter weight with auxiliary winch and wire rope	-9,980	+4,240	-14,220