

TADANO CARGO CRANE

MODEL : **TM-ZE553MH**

CRANE SPECIFICATIONS

<u>CRANE CAPACITY</u>	5,050 kg at 2.5 m (5-part line)
<u>BOOM</u>	Three-sectioned, fully hydraulic telescoping boom of heptagonal box construction Fully retracted length ----- 3.47 m Fully extended length ----- 8.31 m Extending speed ----- 4.84 m in 18 s Elevation ----- Elevated by a double-acting hydraulic cylinder Raising speed ----- 1° to 78° in 12 s Boom point ----- 3 sheaves
<u>WINCH</u>	Hydraulic motor driven Spur gear speed reduction, provided with mechanical brake Single line pull ----- 9.90 kN{1010 kgf} Single line speed ----- 66 m/min (at 4th layer) Wire rope Diameter x length ----- 8 mm x 67 m Breaking strength ----- 50.1 kN{5.1 tf} Construction ----- 7 x 7 + 6 x WS(26) Hook block ----- 2 sheaves
<u>HOOK BLOCK STOWING DEVICE</u>	Hook-in (Mechanically stowed beneath boom top portion)
<u>SLEWING</u>	Hydraulic motor driven Worm gear speed reduction Continuous 360° full circle slewing on ball bearing slew ring Automatic slewing lock Slewing speed ----- 2.5 min ⁻¹ {rpm}

Specifications are subject to change without notice.

OUTRIGGERS

Manually operated beams and hydraulically operated jacks

Integral with crane frame

Extended width ----- Min. 2,200 mm center to center
(2,360 mm outer to outer)Mid. 3,000 mm center to center
(3,160 mm outer to outer)Max. 3,800 mm center to center
(3,960 mm outer to outer)HYDRAULIC SYSTEM

Hydraulic pump ----- Single gear pump

Hydraulic motors ----- Axial piston type for winch

Axial piston type for slewing

Control valves ----- Multiple control valves with integral
safety valve

Oil tank capacity ----- Approx. 57.6L

SAFETY DEVICES

Anti-two-block device

Boom angle indicator

Load indicator

Load meter

Hook safety latch

Spirit level

Hydraulic safety valves, check valves and holding valves

OPTIONAL EQUIPMENT Outrigger pads

Oil cooler

Rear outriggers (outrigger beam non-extension type)

Large capacity oil tank

CRANE MASS

Approx. 1,520 kg

(Except crane options and mounting parts.)

NOTE : Each operating speeds show the value when there is no load conditions and the pump delivery is the following conditions.

- 36 L/min (Slewing speed)
- 60 L/min (BOOM : Extending speed, Raising speed WINCH : Single line speed)

RATED LIFTING CAPACITIES (kg)

Crane Strength Rated Capacities

LOAD RADIUS	3.47 m BOOM	LOAD RADIUS	5.91 m BOOM	LOAD RADIUS	8.31 m BOOM
2.5 m and below	5,050	2.6 m and below	4,050	2.6 m and below	3,130
2.95 m	4,050	2.95 m	4,050	3.0 m	3,130
3.25 m	3,700	3.8 m	3,130	3.8 m	3,130
		4.1 m	2,930	4.1 m	2,930
		4.5 m	2,630	4.5 m	2,630
		5.0 m	2,380	5.0 m	2,380
		5.5 m	2,180	5.5 m	2,180
		5.69 m	2,080	6.0 m	1,980
				6.5 m	1,830
				7.0 m	1,680
				7.5 m	1,530
				8.09 m	1,430

- NOTE :
1. The above numerical values of total rated loads are based on crane strength only. The total rated loads based on stability may lower than those in the above table depending on the loading conditions and the types of the chassis.
 2. This value includes the mass of lifting devices such as hook block (45kg).
 3. This load radius shows actual load radius which includes boom deflection.
 4. If the boom length exceeds the table value even a little, the performance is limited to the performance of the next boom length.

Empty Chassis Rated Capacities

Table A

LOAD RADIUS	3.47 m BOOM		LOAD RADIUS	5.91 m BOOM		LOAD RADIUS	8.31 m BOOM	
	extension width of outriggers			extension width of outriggers			extension width of outriggers	
	MAX.	MIN.		MAX.	MIN.		MAX.	MIN.
2.5 m and below	5,050	2,380	2.6 m and below	4,050	2,380	2.6 m and below	3,130	2,380
2.8 m	4,050	2,130	2.8 m	4,050	2,130	3.4 m	3,130	1,530
3.25 m	3,280	1,680	3.3 m	3,280	1,630	3.8 m	2,680	1,330
			3.6 m	2,930	1,430	4.1 m	2,430	1,180
			4.1 m	2,430	1,180	4.5 m	2,030	980
			4.5 m	2,030	980	5.0 m	1,730	880
			5.0 m	1,730	880	5.5 m	1,430	730
			5.5 m	1,430	730	6.0 m	1,330	630
			5.69 m	1,380	680	6.5 m	1,180	580
						7.0 m	1,030	530
						7.5 m	930	480
						8.09 m	830	430

Table B

LOAD RADIUS	3.47 m BOOM		LOAD RADIUS	5.91 m BOOM		LOAD RADIUS	8.31 m BOOM	
	extension width of outriggers			extension width of outriggers			extension width of outriggers	
	MAX.	MIN.		MAX.	MIN.		MAX.	MIN.
2.5 m and below	5,050	2,980	2.6 m and below	4,050	2,730	2.6 m and below	3,130	2,730
2.95 m	4,050	2,330	2.95 m	4,050	2,330	3.5 m	3,130	1,730
3.25 m	3,650	1,980	3.5 m	3,380	1,730	3.8 m	3,130	1,580
			4.1 m	2,930	1,430	4.1 m	2,930	1,430
			4.5 m	2,480	1,230	4.5 m	2,480	1,230
			5.0 m	2,080	1,030	5.0 m	2,080	1,030
			5.5 m	1,780	930	5.5 m	1,780	930
			5.69 m	1,680	830	6.0 m	1,580	780
						6.5 m	1,430	730
						7.0 m	1,280	650
						7.5 m	1,130	580
						8.09 m	1,030	530

Table C

LOAD RADIUS	3.47 m BOOM		LOAD RADIUS	5.91 m BOOM		LOAD RADIUS	8.31 m BOOM	
	extension width of outriggers			extension width of outriggers			extension width of outriggers	
	MAX.	MIN.		MAX.	MIN.		MAX.	MIN.
2.5 m and below	5,050	3,130	2.6 m and below	4,050	3,130	2.6 m and below	3,130	3,130
2.95 m	4,050	2,730	2.95 m	4,050	2,730	3.0 m	3,130	2,680
3.25 m	3,700	2,380	3.8 m	3,130	1,830	3.8 m	3,130	1,830
			4.1 m	2,930	1,630	4.1 m	2,930	1,630
			4.5 m	2,630	1,430	4.5 m	2,630	1,430
			5.0 m	2,380	1,180	5.0 m	2,380	1,180
			5.5 m	2,130	1,030	5.5 m	2,130	1,030
			5.69 m	2,030	980	6.0 m	1,880	930
						6.5 m	1,730	850
						7.0 m	1,530	780
						7.5 m	1,380	700
						8.09 m	1,230	600

Table D

LOAD RADIUS	3.47 m BOOM extension width of outriggers		LOAD RADIUS	5.91 m BOOM extension width of outriggers		LOAD RADIUS	8.31 m BOOM extension width of outriggers	
	MAX.	MIN.		MAX.	MIN.		MAX.	MIN.
2.5 m and below	5,050	3,280	2.6 m and below	4,050	3,280	2.6 m and below	3,130	3,130
2.95 m	4,050	2,730	2.95 m	4,050	2,730	3.0 m	3,130	2,680
3.25 m	3,700	2,380	3.8 m	3,130	1,830	3.8 m	3,130	1,830
			4.1 m	2,930	1,630	4.1 m	2,930	1,630
			4.5 m	2,630	1,430	4.5 m	2,630	1,430
			5.0 m	2,380	1,180	5.0 m	2,380	1,180
			5.5 m	2,180	1,030	5.5 m	2,180	1,030
			5.69 m	2,080	980	6.0 m	1,980	930
						6.5 m	1,830	850
						7.0 m	1,680	780
						7.5 m	1,530	700
						8.09 m	1,430	600

- NOTE :
1. Empty Chassis Rated Capacities in these tables depend on condition that crane is set level on firm level ground.
 2. This value includes the mass of lifting devices such as hook block (45kg).
 3. When the outriggers are extended to the middle width, read the capacities rated for the minimum extension width.
 4. This load radius shows actual load radius which includes boom deflection.
 5. If the boom length exceeds the table value even a little, the performance is limited to the performance of the next boom length.
 6. Empty chassis rated lifting capacity varies according to the working area.
 <over-side, over-rear area> : 100%
 <over-front area> : 25%
 7. Empty Chassis Rated Capacities table A, B, C and D depend on the types of chassis. (The following table shows guidelines for bodywork vehicles that can achieve the rated lifting capacity tables A, B, C and D for vehicles. Be sure to carry out a stability inspection to determine which performance to apply.)

A	14.6 t ≤ GVW < 20 t
B	15 t ≤ GVW < 20 t, 3.8 t ≤ CAWf (*1)
C	20 t ≤ GVW < 25 t, 3.8 t ≤ CAWf (*1)

*1 : Chassis front axle weight (excluding crane and mounting parts mass).

Extension mark

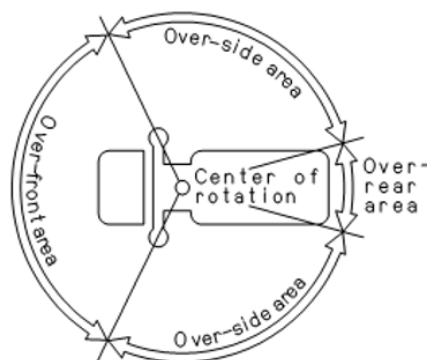
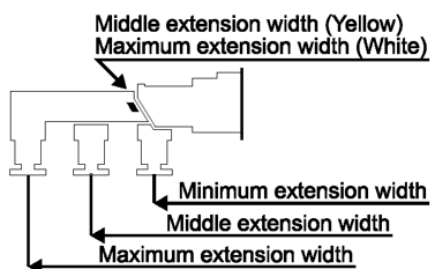

WORKING RANGE

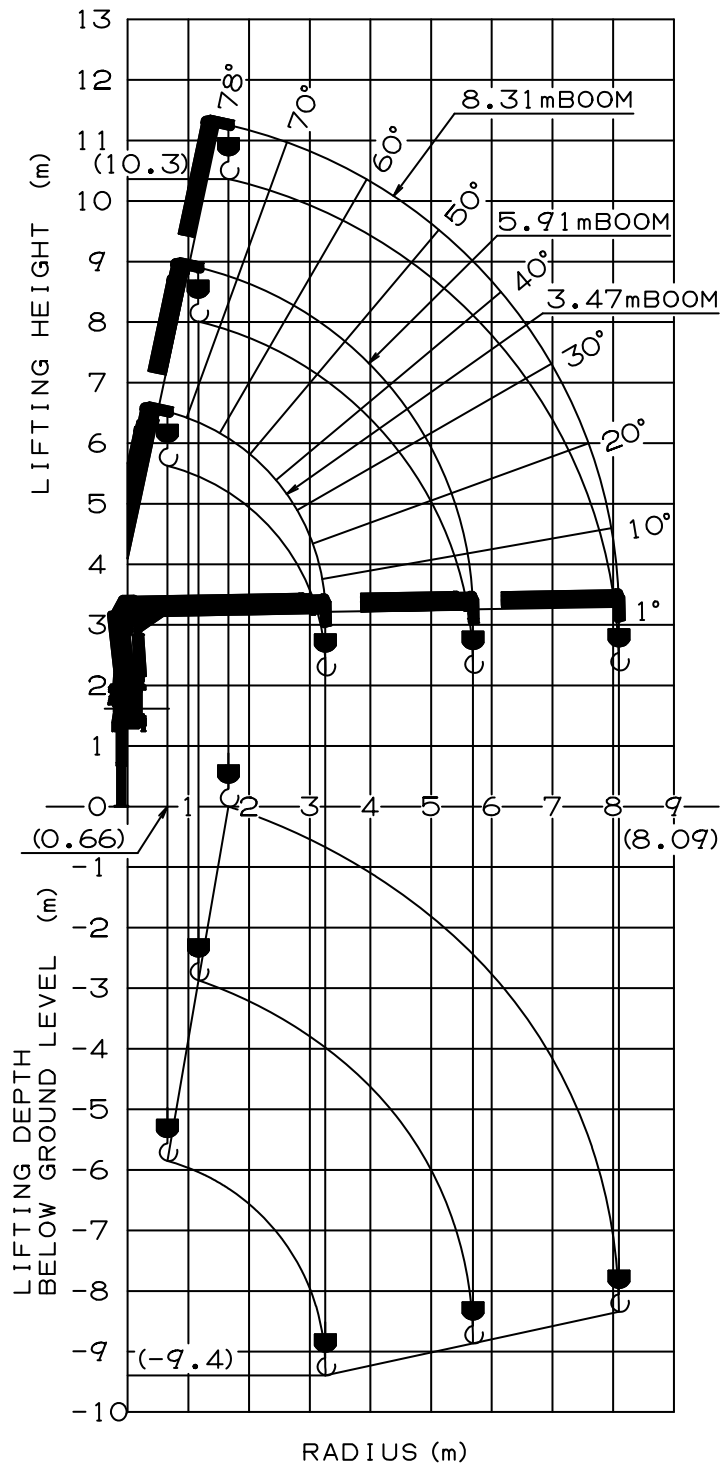

NOTE : The above lifting heights and boom angles are based on a straight (unladen) boom, and allowance should be made for boom deflection obtained under laden conditions.

DIMENSIONS

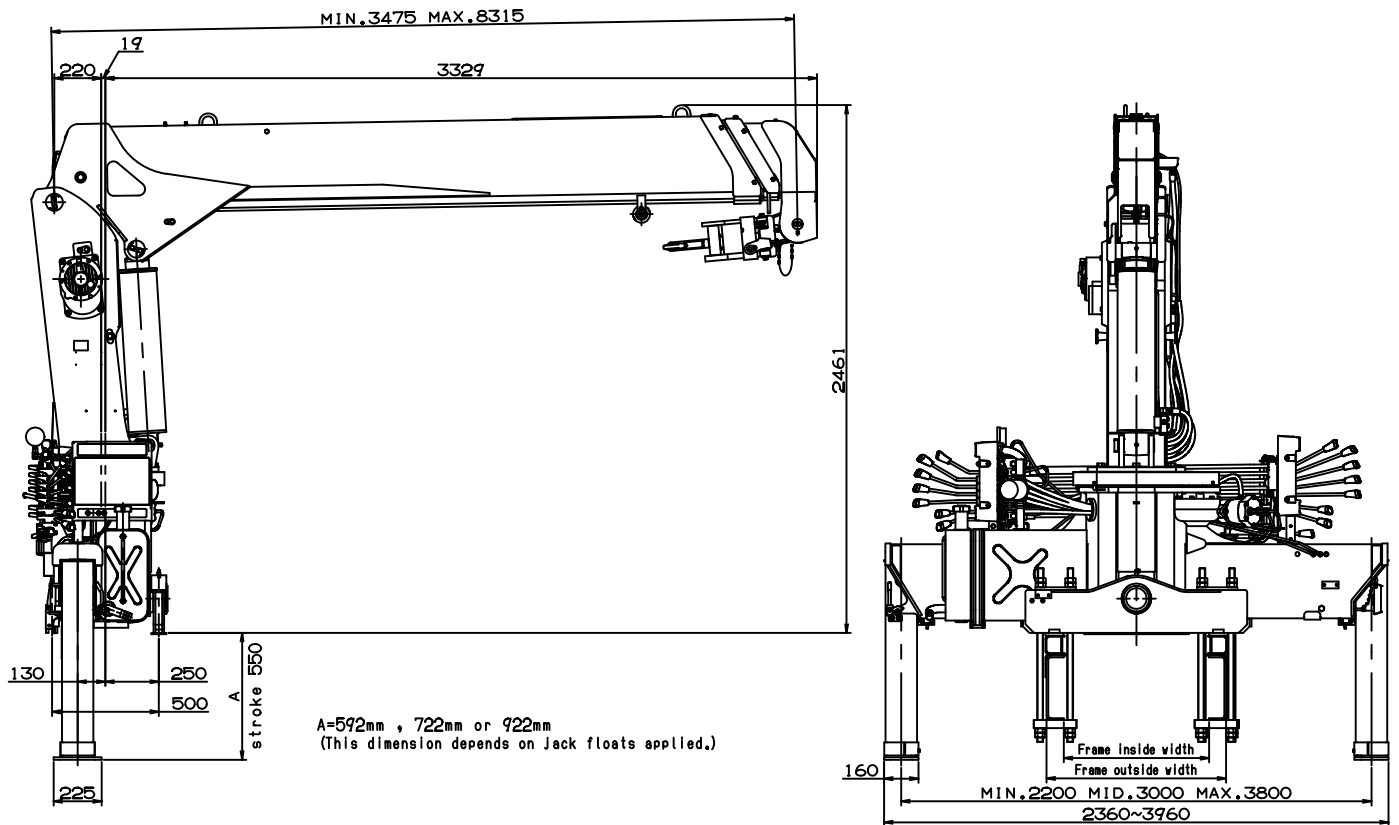

GENERAL DATA FOR SUITABLE TRUCKS

Gross vehicle weight	15,000 to 25,000 kg
P.T.O. torque	190 N·m {19.4 kgf·m} min.
P.T.O. revolution range of use (min. to max.)	Approx. 350 to 1,300 min ⁻¹ {rpm}
Width for crane mounting	Approx. 750 mm min.
Frame	Weight distribution and frame strength should be calculated for each truck
Frame width range (inside to outside)	Approx. 610 to 960 mm
Frame height (ground to chassis frame top) (*1)	Approx. 700 to 1,445 mm
Chassis frame section modulus (*2)	485 cm ³ min.

*1 Height of crane mounting surface is changed by crane bases.

*2 The chassis frame material must meet the following conditions at the crane mounting location.

— Yield point : 392 N/mm²

— Tensile strength : 540 N/mm²